

ROOFING & WALLING INSTALLATION MANUAL



FOR DESIGN AND INSTALLATION PROFESSIONALS



INSPIRATION TO BUILD BETTER

AUSTRALIAN STANDARDS

Australian Standard	Definition
AS 1397:2021	Continuous hot-dip metallic coated steel sheet and strip — Coatings of zinc and zinc alloyed with aluminium and magnesium
AS 1562.1:2018	Design and installation of metal roof and wall cladding, Part 1: Metal
AS 3566.1-2002	Self drilling screws for building and construction Industries Part:1 General requirements and mechanical properties
AS 3959:2018	Construction of buildings in bushfire-prone areas
AS 4040.1-1992 (Reconfirmed 2016)	Methods of testing sheet roof and wall cladding - Method 1: Resistance to concentrated loads
AS 4040.2-1992 (Reconfirmed 2016, Amendment 1:2018)	Methods of testing sheet roof and wall cladding, Method 2: Resistance to wind pressures for non-cyclone regions
AS/NZS 1170.2:2021	Structural design actions, Part 2: Wind actions
AS/NZS 2179.1:2014	Specifications for rainwater goods, accessories and fasteners
AS/NZS 2728:2013	Prefinished/prepainted sheet metal products for interior/exterior building applications - Performance requirements
AS/NZS 3500.3:2021	Plumbing and Drainage-Part 3: Storm water drainage
SA HB 39:2015	Installation code for metal roof and wall cladding
HB 114:1998	Guidelines for eaves and box gutters

Contents

1.0 INTRODUCTION & GENERAL NOTES	4	PART B: INSTALLATION	
PART A: DESIGN		7.0 GENERAL CARE, SAFETY AND HANDLING	30
2.0 DESIGN PRELIMINARIES	6	7.1 Safety	30
2.1 Product selection	6	7.2 Care and storage before installation	30
2.2 Materials and finishes	6	7.3 Handling cladding on site	30
2.3 Support spacing and overhang	6	7.4 Walking on roofs	30
2.4 Maximum lengths of roofing	6	7.5 Marking out, cutting and drilling	30
2.5 Low roof pitches	7	7.6 Clean up	31
2.6 Wind forces on roofs	7	7.7 Warn other contractors	31
2.7 Codes and performance tests	7	7.8 Strippable coatings	31
2.8 Environmental conditions	7	7.9 Recommended Sealants	31
2.9 Metal and timber compatibility	7	7.10 Maintenance	32
2.10 Transportation	8	8.0 INSTALLING PIERCE-FIXED CLADDING	33
2.11 Paint and COLORBOND® steel finishes	8	8.1 General installation procedure	33
2.12 Specifications - roofing	9	8.2 Side-lapping & positioning pierce-fixed sheets	34
2.13 Specifications - walling	10	8.3 Pierce-fixing on crests	34
2.14 Maximum roof lengths for drainage	11	8.4 Pierce-fixing on valleys (for walling only)	35
3.0 FASTENERS	12	8.5 Pierce-fixing on side-laps	35
3.1 Materials for screws	12	9.0 INSTALLING CONCEALED-FIXED CLADDING	36
3.2 Materials for nails	12	9.1 Installing KLIP-LOK® roofs	36
3.3 Materials for blind rivets	12	9.2 Installing KLIP-LOK® walls	36
3.4 Materials for sealing washers	12	10.0 ENDS OF SHEETS	43
3.5 Identification of screws	12	10.1 Turn-ups	43
3.6 Setting of screws	13	10.2 Turning-down	45
3.7 Quantity of fasteners and clips	14	10.3 Blocking off rib cavities	45
3.8 Recommended fasteners and locations	14	10.4 End-lapping	46
4.0 CURVED, BENT & TAPERED CLADDING	19	10.5 Expansion	48
4.1 Spring-curved-ridge roof	19	10.6 Roof overhang with edge stiffener	49
4.2 Spring-arched roof	20	10.7 Sheet-ends on low slopes	49
4.3 Spring-curved concave roofs	21	11.0 FLASHINGS	50
4.4 Pre-curved sheets	21	11.1 Materials	50
4.5 Capped bent ribbed roofs	22	11.2 Longitudinal flashings	50
5.0 INSULATION & SKYLIGHTS	23	11.3 Transverse flashings	51
5.1 Heat control	23	11.4 Flashing at change of pitch	53
5.2 Condensation	24	11.5 Flashing large roof penetrations	53
5.3 Noise reduction	25	11.6 Flashing small roof penetrations	55
5.4 Insulation materials	25	11.7 Flashing walls	56
5.5 Insulation thickness	25	11.8 Bushfire protection	58
5.6 Skylighting	26	REFERENCES	59
6.0 ROOF DRAINAGE	27	INDEX	60
6.1 Introduction	27		
6.2 Design of drainage (eaves-gutter system)	27		

ROOFING & WALLING

1.0 INTRODUCTION & GENERAL NOTES

BlueScope and Lysaght may make changes to this Manual in their sole discretion. You should check you are using the most up-to-date version of the Manual before you start construction. We also have specific publications for all of our products, and you should use them in conjunction with this manual.

SCOPE

This manual is a guide to the design and installation of steel roofing and walling manufactured by Lysaght. We intend that it be used by all trades and professions involved with specifying and applying the wide range of our products.

We refer only to genuine steel roofing and walling manufactured by us and marketed under our brand names. Our recommendations should only be used for our products because they are based on comprehensive testing of our profiles, base metal thicknesses (BMT) and material finishes.

CONDITIONS OF USE

If you use this Manual, you acknowledge and agree that your use is subject to the terms and conditions in this Manual. Lysaght, its agents, officers, employees, sub-contractors or consultants make no representations, either expressed or implied, as to the suitability of the information and data in this Manual for your particular purposes. It's your responsibility to ensure the design you use is appropriate for your needs, the products you have purchased, your site and structural limitations and your building and construction capabilities.

This Manual endeavours to present information on products, details, installation and practices in a clearly prescribed manner and it is the user's responsibility to apply the information in the way intended. If there is any uncertainty then it is the user's responsibility to seek clarification.

Where we recommend use of third party materials, ensure you check the qualities and capabilities of those products with the relevant manufacturer before use.

USE OF GENUINE MATERIALS

Structures in this Manual should only be built or constructed using genuine LYSAGHT® or recommended third party products. Except as otherwise provided in these terms, any warranties only apply to you (if at all) if you use the recommended genuine LYSAGHT® or third party products and method of construction.

CHECK DELIVERY

It is important that you check all materials delivered to site against your invoice before you use them in your building or construction to ensure all components have arrived, are of the appropriate quality and are ready for installation.

WARRANTIES

For over 150 years we have consistently manufactured the highest quality building products. The LYSAGHT® brand is synonymous with Australian building.

Our continuing confidence in our products is shown in the warranties we offer.

Our products are engineered to perform according to our specifications only if they are used in the appropriate conditions and installed to the recommendations in this manual and our other publications.

Naturally, the warranties require specifiers and installers to exercise due care in how the products are applied and installed and are subject to final use and installation. Also, owners need to maintain the finished work.

We invite you to ask about the warranties applicable to your proposed purchase, at your supplier of LYSAGHT® products.

GENERAL NOTES TO READ BEFORE YOU USE THIS GUIDE

This Manual has been prepared for a range of roofing and walling applications including water drainage systems, using products manufactured or supplied by Lysaght.

CYCLONIC AREAS

In general, this book refers to non-cyclonic conditions. Design information for cyclonic areas is in our Cyclonic Area Design Manual. The information in this booklet is suitable for use only in areas where a tropical cyclone is unlikely to occur as defined in AS/NZS 1170.2 Part 2: Structural Actions - Wind Actions (or if used outside Australia, to the equivalent standard).

Information on cyclonic performance may be found in our Cyclonic Area Design manual which is available on-line at www.lysaght.com.

PROFESSIONAL ADVICE

All erection and connection details are to be made in accordance with the relevant standard connection details drawing contained in this Manual.

We recommend you get professional advice to ensure your particular needs are adequately met.

Before you commence construction:

- you should check with your local government authority to see if any form of prior permission or approval is required;
- if you want to build or construct any attached structure, you should seek advice from a suitably qualified engineer to verify the capacity of your existing structure to withstand any additional load arising from the attached structure. You should also check with your local government authority to determine any specific requirements for the attachment to existing structures;
- you should check with your local workplace health and safety authority to see what safety measures you need to put in place prior to and during construction. It is the responsibility of the installer/erector to ensure all local safe work practices are adhered to and the safety of the whole site is maintained at all times.

To ensure maximum lifespan of your building, consult your nearest LYSAGHT® branch for information regarding maintenance, handling, storage and any other technical assistance you may require.

Previously published as:

LYSAGHT® Roofing & Walling Users Guide
Steel Roofing and Walling: Installation Manual, and
Using LYSAGHT® Roofing and Walling

YOUR SUGGESTIONS

Please send your suggestions for improvements to this manual to marketing@lysaght.com.

FURTHER INFORMATION ON PRODUCTS AND SERVICES

WWW.LYSAGHT.COM

Your supplier of LYSAGHT® products

LYSAGHT® Information Service on 1800 641 417



Contemporary and traditional, residential or commercial: all are accomplished with ease using LYSAGHT® building products.



PART A: DESIGN

2.0 DESIGN PRELIMINARIES

2.1 PRODUCT SELECTION

When you design steel cladding into your building you have a wide range of profiles from which to choose. Whilst roofing and walling obviously have to keep out the weather, they also have significant effects on the looks, cost and durability of a building.

If you are unsure about any product feature, visit www.lysaght.com, call our information line or seek advice from the relevant specialists.

WALLS

The design of walling from a steel perspective is fairly straightforward. Once you have made the aesthetic decision of which profile to use, the main considerations are the support spacings (Section 2.3), fixing details (Chapter 3) and the details of flashing (Chapter 11).

ROOFS

There are many factors in designing roofs including:

- the shape: is the roof to be 'flat' or pitched or curved?
- the supporting structure and support spacing;
- the wind forces that the roof must sustain;
- the pitch which affects the looks, the profile's ability to efficiently carry rain to the gutters, and fixing details;
- thermal expansion of long sheets (Chapter 10);
- the attributes of other materials used in the roof design.

This manual doesn't attempt to cover the structural design details of supports or aesthetics: there are many other texts and Australian Standards that cover them. The aesthetic aspects of steel roofing and walling, and its installation, have particular characteristics and you should get advice from relevant specialists where required.

This chapter gives tables of recommended support spacings, and the maximum roof length for pitch and rainfall intensity for LYSAGHT® steel roofing products.

The appropriate design will depend on your particular needs and circumstances. You should get advice from the relevant specialists where required.

2.2 MATERIALS AND FINISHES

Our most widely used cladding profiles are listed in Tables 2.12.1 and 2.13.1. They are available in COLORBOND® pre-painted steel, or in unpainted ZINCALUME® magnesium/aluminium/zinc alloy-coated steel.

MATERIAL SPECIFICATIONS

- Next generation ZINCALUME® aluminium/zinc/magnesium alloy coated steel complies with AS 1397 G550, AM125 (550 MPa minimum yield stress, 125g/m² minimum coating mass).
- COLORBOND® steel is pre-painted steel for exterior roofing and walling. It is the most widely used. The painting complies with AS/NZS 2728 and the steel base is an aluminium/zinc alloy-coated steel complying with AS 1397. Minimum yield strengths are G550 (550 MPa), or G300 (300 MPa) depending on profile. Minimum coating mass is AM100 (100g/m²).
- COLORBOND® Metallic steel is pre-painted steel for superior aesthetic qualities displaying a metallic sheen.
- COLORBOND® Ultra steel is pre-painted steel for severe coastal

or industrial environments (generally within about 100m - 200m of the source). The painting complies with AS/NZS 2728 and the steel base is an aluminium/zinc alloy-coated steel complying with AS 1397. Minimum yield strength is G550 (550 MPa). Minimum coating mass is AM150 (150g/m²).

- SUPERDURA® Stainless steel is a pre-painted steel for severe coastal or industrial environments. The painting complies with AS/NZS 2728 and the steel base is a stainless steel complying with AISI/ASTM Type 430; UNS No. S43000.

Check with your local Lysaght office for availability of profiles, materials, finishes, colours, accessories; and for suitability of the product.

Tables 2.12.1 and 2.13.1 list general information for profile selection. Refer to our publications on specific products for detailed specifications. There are also publications on ZINCALUME® steel and COLORBOND® pre-painted steel from our information line (Page 1).

2.3 SUPPORT SPACING AND OVERHANG

The maximum recommended support spacings for end and internal spans are shown in Tables 2.12.1 and 2.13.1. For roofs the maximum recommended support spacing is based on data in accordance with AS 1562.1 Design and installation of sheet roof and wall cladding: Metal, and AS 4040.1 Methods of testing sheet roof and wall cladding—Resistance to concentrated loads.

The roof spacings in the tables are recommended to produce adequate performance of claddings under concentrated loading (incidental for maintenance).

For support spacings in wind conditions, refer to our publications on specific products for wind pressure data.

The overhang is the projection of the sheet past a support. The minimum overhang must consider:

- The minimum recommended end distance of the cladding's fastener / clip.
- The industries requirement for projection of the cladding into a gutter (box, valley or eaves).

The maximum overhang is shown in Table 2.12.1 and 2.13.1.

For roofs the maximum overhang is a guide and is based on a nominal incidental load applied adjacent to the free edge. All roof overhangs should be treated as a non-trafficable area. When a roof overhang exceeds the guide then added care should be considered with respect to providing stiffening or support to minimise the potential of damage from accidental loading.

2.4 MAXIMUM LENGTHS OF ROOFING

The valleys (or pans) of roofing have to carry water to the gutters. If in heavy rain, the valleys overflow, water can flow into the roof through the side-laps and flashings.

Factors affecting waterproof and drainage capacity of the laps of a profile include:

- the width and depth of the valleys or pans;
- the pitch of the roof—rain flows faster on a steeper pitch;
- rainfall intensity for the geographical area;
- the length of the roof from ridge to gutter; and
- penetrations that cause nearby valleys to carry extra rain diverted from valleys obstructed by the penetration (Figure 2.14.1).

The maximum recommended roof lengths for drainage for each profile are given in Table 2.14.1.

2.5 LOW ROOF PITCHES

Unless there is adequate positive fall in a roof, there is danger of ponding, which can lead to a reduced service life, or reduced rainwater capacity. Reduced service life is of particular importance in more severe environment.

At low slopes, say around 2° or less slope, all roof supports must be in the one plane because slight variations can result in zero or negative fall. This may occur during construction, or even after completion of the building as the result of construction tolerances/practices, settlement, timber warping or shrinking, or extra loadings (like air conditioners) or suspended services.

Minimum recommended roof slopes are listed in Table 2.12.1. As a guide, wherever possible, you should design for a minimum slope of 1 in 30 (2°).

Roof slopes lower than the recommended minimum may be available subject to enquiry and will be dependent upon the roof application and building details. Lower roof slopes may require additional provisions to be adhered to. Please call your nearest service centre for advice.

2.6 WIND FORCES ON ROOFS

Winds create considerable forces on both the topside and the underside of roof cladding, and you must consider these forces in the design and fixing of any roof. The forces are:

- **inward forces** tending to collapse the roof cladding inwards, caused by wind acting directly on the windward side; and
- **outward forces** tending to lift the roof cladding from its framing, and the entire roof structure from the rest of the building. Outward forces can be caused both by uplift from negative wind pressures, outside the building; and by positive wind pressure inside the building.

Generally the greatest wind forces imposed on roofs are due to the outward forces. Because the dead weight of roofing materials is relatively small, the outward forces must be resisted by the roof fasteners.

It is very important that the battens and roof framing are adequately fixed to the rafters and walls, and that under extreme conditions the wall framing is anchored to the footings. Special anchoring provisions may apply in cyclonic areas. Specialist advice should be sought in these circumstances.

2.7 CODES AND PERFORMANCE TESTS

AS 1562.1 specifies the design and installation of sheet metal roof and wall cladding. Our roofing profiles satisfy all the requirements of this standard, including the ability of the roof to resist outward forces and concentrated loads. The testing is performed according to AS 4040.

Metal roofing products must comply with the performance specifications, and be checked by stringent tests, in accordance with the standard. Such tests have been carried out on all our claddings and the results have been used in the preparation of the fixing and installation recommendations in this manual.

2.8 ENVIRONMENTAL CONDITIONS

Coated steel products can be damaged by some environmental conditions including industrial, agricultural, marine, intensive animal farming, swimming pools or other aggressive conditions. If any of our products are to be used in these conditions, or unusually corrosive environments, seek advice from our information line (Page 1).

Keep the product dry and clear of the ground. If stacked or bundled product becomes wet for extended periods, separate it, wipe it with a clean cloth and stack it to dry thoroughly.

2.9 METAL AND TIMBER COMPATIBILITY

Contact with (or run-off from) some materials can damage coated steel products. Buildings can also be susceptible to condensation on inside surfaces.

The materials include certain metals, treated timbers and chemicals.

- Don't allow any contact of coated steel products with incompatible materials. (Table 2.9.1).
- Don't allow discharge of rainwater from incompatible materials onto coated steel products. (Table 2.9.1).
- Ensure that supporting members are compatible with the coated steel products or, alternatively, appropriately coated.

If there are doubts about the compatibility of other products being used, seek advice from our information line.

Incompatible materials include:

- lead
- copper
- monel metal
- bare steel
- stainless steel (except with SUPERDURA® Stainless steel cladding)
- carbon (in pencils and some rubbers)
- green or some chemically-treated timber (like CCA or tanalith treatments)
- materials subject to cycles of dryness and wetness or which have excessive moisture content (such as improperly-seasoned timber)
- wet and dry concrete
- soils
- vegetable matter
- cleaning agents (e.g. brick cleaning)
- any material which will inhibit normal exposure to the atmosphere

TABLE 2.9.1:

Acceptability of drainage from upper surface onto a lower metal surface and direct contact.

COMPATIBILITY OF DIRECT CONTACT BETWEEN METALS OR ALLOYS

ROOF DRAINAGE SYSTEM COMPONENTS & ANY CLADDING MATERIAL	ACCESSORIES OR FASTENER OR (UPPER SURFACE)									
	ZINCALUME® steel	Galvanised (Zinc coated steel)	Zinc	COLORBOND® steel, COLORBOND® Ultra steel, COLORBOND® Metallic steel	SUPERDURA® Stainless steel	Stainless steel	Aluminium alloys	Copper & copper alloys ⁽¹⁾	Lead	
ZINCALUME® steel	YES	YES	YES	YES	NO	NO	YES	NO	NO	
Galvanised (Zinc coated steel)	YES	YES	YES	YES	NO	NO	YES	NO	NO	
ZINC	YES	YES	YES	YES	NO	NO	YES	NO	NO	
COLORBOND® steel, COLORBOND® Ultra steel, COLORBOND® Metallic steel	YES	YES	YES	YES	NO	NO	YES	NO	NO	
SUPERDURA® Stainless steel	NO	NO	NO	NO	YES	YES	NO	NO	NO	
Stainless steel	NO	NO	NO	NO	YES	YES	NO	NO	NO	
Aluminium alloys	YES	YES	YES	YES	NO ⁽³⁾	NO ⁽³⁾	YES	NO	NO	
Copper & copper alloys ⁽¹⁾	NO	NO	NO	NO	NO	NO	NO	YES	NO	
Lead	NO	NO	NO	NO	NO	NO	NO	YES	YES	

⁽¹⁾ Monel - copper/nickel alloy.

⁽²⁾ For further guidance refer to AS/NZS 3500.3.

⁽³⁾ In benign environments, mixing of stainless steel and aluminium may be acceptable.

ACCEPTABILITY OF DRAINAGE FROM AN UPPER SURFACE TO A LOWER METAL SURFACE

LOWER ROOF DRAINAGE SYSTEM MATERIAL	ACCESSORIES OR FASTENER OR (UPPER SURFACE)										
	ZINCALUME® steel	Galvanised (Zinc coated steel)	Zinc	COLORBOND® steel, COLORBOND® Ultra steel, COLORBOND® Metallic steel	SUPERDURA® Stainless steel	Stainless steel	Aluminium alloys	Copper & copper alloys ⁽¹⁾	Lead	Glazed roof tiles, Glass & plastic	
ZINCALUME® steel	YES	YES	YES	YES	YES	YES	YES	NO	NO	YES	
Galvanised (Zinc coated steel)	NO	YES	YES	NO	NO	NO	NO	NO	YES	NO	
Zinc	NO	YES	YES	NO	NO	NO	NO	NO	YES	NO	
COLORBOND® steel, COLORBOND® Ultra steel, COLORBOND® Metallic steel	YES	YES	YES	YES	YES	YES	YES	NO	NO	YES	
SUPERDURA® Stainless steel	YES	YES	YES	YES	YES	YES	YES	YES	YES	YES	
Stainless steel	YES	YES	YES	YES	YES	YES	YES	YES	YES	YES	
Aluminium alloys	YES	YES	YES	YES	YES	YES	YES	NO	NO	YES	
Copper & copper alloys ⁽¹⁾	YES	YES	YES	YES	YES	YES	YES	YES	YES	YES	
Lead	YES	YES	YES	YES	YES	YES	YES	YES	YES	YES	

⁽¹⁾ Monel - copper/nickel alloy.

⁽²⁾ For further guidance refer to AS/NZS 3500.3.

2.10 TRANSPORTATION

Because our roofing and walling is manufactured by continuous processes, sheet lengths can be supplied up to the limits of transport regulations, which vary from state to state.

KLIP-LOK 700 HI-STRENGTH® is available in extra long lengths via an on-site mobile rollformer. This service is available nationally, subject to enquiry.

2.11 PAINT AND COLORBOND® STEEL FINISHES

COLORBOND® steel finishes can be damaged by some handling, installation or maintenance activities. If damage occurs to the COLORBOND® steel pre-painted finish, refer to Technical Bulletin TB-2, published by BlueScope.











Replacement of severely damaged COLORBOND® steel should consider that the replacement sheet may not match perfectly due to the possible long term fading of the installed sheets exposed to weathering.

You may overpaint whole roofs and paint accessories to match specific colours. The overpaint guidelines are also discussed in Technical Bulletin TB-2.

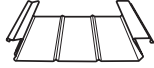
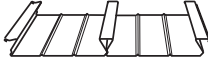
2.12 SPECIFICATIONS - ROOFING

TABLE 2.12.1:

Specifications of roofing & walling profiles.

	BMT	Mass ⁽¹⁾	Cover Width	Rib Depth	Roof Pitch Minimum ⁽²⁾	Maximum recommended spacing of supports ⁽⁷⁾									
						ROOFS			Eaves Overhang ⁽³⁾		WALLS				
						Single	End	Internal	Unstiffened	Stiffened	Single	End	Internal	Overhang	
	mm	kg/m ²	mm	mm	Degrees	mm	mm	mm	mm	mm	mm	mm	mm	mm	mm
CUSTOM ORB [®]	0.42	4.23	762	16	5 (1 in 12)	700	900	1200	200	300	1800	2500	2700	200	
	0.48	4.81	762	16	5 (1 in 12)	800	1300	1700	250	350	1800	2700	2700	250	
CUSTOM BLUE ORB [®]	0.60	6.1	762	17	5 (1 in 12)	1600	1600	1800	200	300	2400	3000	3300	200	
	0.80	8.0	762	17	5 (1 in 12)	1800	1800	2600	400	600	2400	3200	3600	400	
CUSTOM ORB ACCENT 21 [®]	0.40	4.4*	762	21	3 (1 in 20)	750	950	1350	150	400	1800	2400	2400	150	
	0.48	5.2*	762	21	3 (1 in 20)	950	1500	1900	200	450	1800	2700	2700	200	
CUSTOM ORB ACCENT 35 [®]	0.48	5.5*	724	35	2 (1 in 30)	1300	1600	2400	200	600	2100	2700	2700	200	
															
FLATDEK [®] (5)	0.42	6.04	250	45	2 (1 in 30)	2100	2600	2600	-	-	-	-	-	-	
															
FLATDEK [®] II (4)	0.42	5.20	620	45	2 (1 in 30)	2100	2600	2600	-	-	-	-	-	-	
															
KLIP-LOK [®] 406	0.48	5.56	406	41	1 (1 in 50)	1500	1800	2100	200	600	-	-	-	-	
															
KLIP-LOK 700 HI-STRENGTH [®]	0.42	4.61	700	43	2 (1 in 30) (6)	1650	1750	2200	150	450	2600	3000 (8)	3000 (8)	150	
	0.48	5.24	700	43	1 (1 in 50)	2050	2350	2800	200	500	3000	3000 (8)	3000 (8)	200	
KLIP-LOK CLASSIC [®] 700	0.42	4.61	700	40	2 (1 in 30) (6)	1600	1800	2600	200	500	2000	2300	3000 (8)	300	
	0.48	5.24	700	40	1 (1 in 50)	2000	2100	3000 (8)	250	600	2450	2550	3000 (8)	400	
SPANDEK [®]	0.42	4.61	700	24	3 (1 in 20) (5)	1300	1800	2400	300	600	2500	3000	3300	300	
	0.48	5.24	700	24	3 (1 in 20) (5)	2000	2200	3000	400	700	3000	3000	3300	400	
TRIMDEK [®]	0.42	4.23	762	29	2 (1 in 30)	1100	1300	1900	150	300	2400	3000	3000	150	
	0.48	4.81	762	29	2 (1 in 30)	1600	1850	2600	200	350	2700	3000	3000	200	

⁽¹⁾ Masses are for unpainted ZINCALUME[®] steel, unless otherwise marked (*). * which are indicative masses only.

⁽²⁾ See Section 2.5, LYSAGHT[®] Roofing & Walling Installation Manual.

⁽³⁾ See Section 10.6 for explanation of 'stiffened'.

⁽⁴⁾ FLATDEK[®] & FLATDEK[®] II are Home Improvement profiles.

⁽⁵⁾ Slope of 2° (1 in 30) is below the minimum recommended however is available subject to enquiry. Please refer to Section 2.5, LYSAGHT[®] Roofing & Walling Installation Manual.

⁽⁶⁾ Slope of 1° (1 in 50) is below the minimum recommended however is available subject to enquiry. Please refer to Section 2.5, LYSAGHT[®] Roofing & Walling Installation Manual.





⁽⁷⁾ See Section 2.3, LYSAGHT[®] Roofing & Walling Installation Manual.

⁽⁸⁾ Spans in excess of 3000mm may be available subject to enquiry.

2.13 SPECIFICATIONS - WALLING

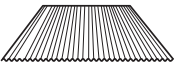
TABLE 2.13.1:

Specifications of profiles for walling only.

	BMT	Mass ⁽¹⁾	Cover Width	Rib Depth	Maximum recommended spacing of supports ⁽²⁾			
					Single	End	Internal	Overhang
	mm	kg/m ²	mm	mm	mm	mm	mm	mm
MINI ORB® 	0.42	3.93	820	6	1200	1500	1500	100
MULTICLAD® 	0.35	3.23	840	12	1400	1800	1800	150
PANELRIB® 	0.35	3.19	850	4	1100	1200	1200	150
	0.42	3.80	850	4	1200	1200	1200	150
TRIMWALL® 	0.35	3.56	762	29	2100	2900	3000	150
WALLCLAD® 	0.35	3.56	762	16	1800	2400	2400	150

⁽¹⁾ Masses are for unpainted ZINCALUME® steel.

⁽²⁾ See Section 2.3, LYSAGHT® Roofing & Walling Installation Manual.

Roofing & Walling Profiles

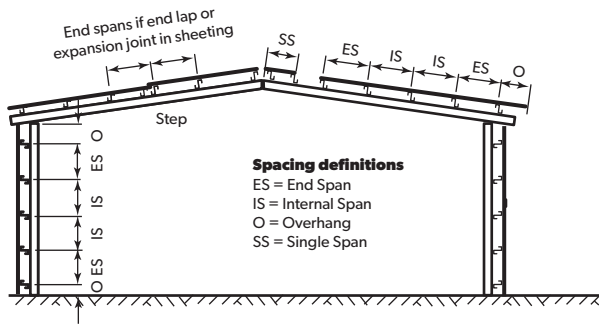

Walling Profiles Only

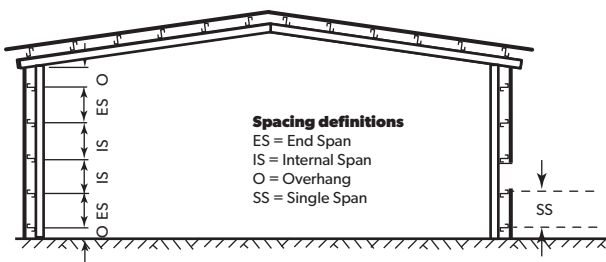

2.14 MAXIMUM ROOF LENGTHS FOR DRAINAGE

TABLE 2.14.1:

Maximum roof lengths for drainage measured from ridge to gutter (m) Penetrations alter the flow of water on a roof. Thus, for design, you need to use an effective roof length (Figure 2.14.1).

	Peak Rainfall Intensity	Roof Slope					
		1 in 50 (1°)	1 in 30 (2°)	1 in 20 (3°)	1 in 12 (5°)	1 in 7.5 (7.5°)	1 in 6 (10°)
CUSTOM ORB® CUSTOM BLUE ORB®	100			29	34	38	
	150			20	23	25	
	200			15	17	19	
	250			12	14	15	
	300			10	11	13	
	400			7	8	10	
	500			6	7	8	
CUSTOM ORB ACCENT® 21	100		38	46	53	60	
	150		25	31	35	40	
	200		19	23	27	30	
	250		15	18	21	24	
	300		13	15	18	20	
	400		10	11	13	15	
CUSTOM ORB ACCENT® 35	100		90	103	124	143	161
	150		60	69	82	95	107
	200		45	51	62	72	80
	250		36	41	49	57	64
	300		30	34	41	48	54
	400		23	26	31	36	40
KLIP-LOK® 406	100	375	467	548	682	813	934
	150	250	311	365	454	542	623
	200	188	234	274	341	406	467
	250	150	187	219	273	325	374
	300	125	156	183	227	271	311
	400	94	117	137	170	203	234
	500	75	93	110	136	163	187
KLIP-LOK 700 HI-STRENGTH®	100	344	428	502	624	745	856
	150	229	285	334	416	496	571
	200	172	214	251	312	372	428
	250	137	171	201	250	298	342
	300	115	143	167	208	248	285
	400	86	107	125	156	186	214
KLIP-LOK CLASSIC® 700	100	247	308	361	449	536	616
	150	165	205	241	300	357	411
	200	124	154	181	225	268	308
	250	99	123	144	180	214	246
	300	82	103	120	150	179	205
	400	74	93	108	135	161	185
500	49	62	72	90	107	123	

	Peak Rainfall Intensity	Roof Slope					
		1 in 50 (1°)	1 in 30 (2°)	1 in 20 (3°)	1 in 12 (5°)	1 in 7.5 (7.5°)	1 in 6 (10°)
SPANDEK®	100		97	111	133	154	173
	150		65	74	89	103	115
	200		49	55	67	77	86
	250		39	44	53	62	69
	300		32	37	44	51	58
	400		24	28	33	39	43
	500		19	22	27	31	35
TRIMDEK®	100		220	257	320	382	439
	150		146	172	214	255	293
	200		110	129	160	191	220
	250		88	103	128	153	176
	300		73	86	107	127	146
	400		55	64	80	96	110
	500		44	51	64	76	88

Notes:

- Some lengths in this table may exceed the maximum allowable transport length.
- Data are based on work of CSIRO and LYSAGHT®.
- For peak rainfall intensities in your locality, see Chapter 6 unless noted otherwise.
- FLATDEK® and FLATDEK® II are recommended for home improvement use only (carports/verandahs) where weathertightness is not of primary importance. Drainage figures are therefore not supplied.
- SPANDEK® with slope of 2° (1 in 30) is below the minimum recommended however is available subject to enquiry. Please refer to Section 2.5.
- CUSTOM ORB ACCENT® data are based on proprietary design.

FIGURE 2.14.1:

Example of calculating effective roof lengths where penetrations alter the flow of water on a roof.

Note: A suitably qualified engineer is recommended for calculating/checking roof design and flow design.

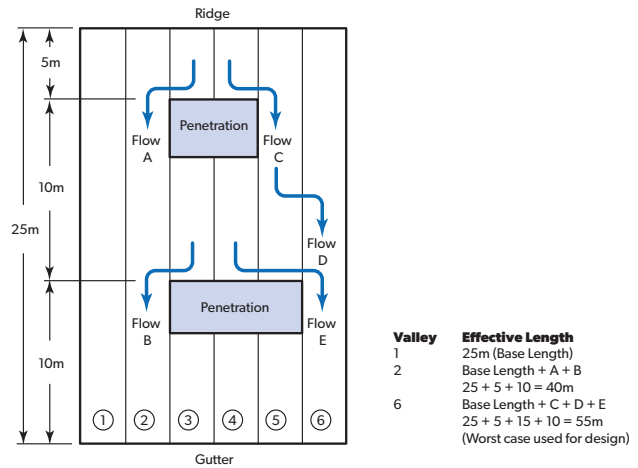

The cross section drainage area for individual pans/valleys for a range of LYSAGHT® roof profiles is set out at Table 2.14.2

TABLE 2.14.2:

Profile	Roof Profile Type	a' (mm ²)
CUSTOM ORB®	Rounded Trapezoidal	188.3
CUSTOM ORBACCENT® 21	Rounded Trapezoidal	267
CUSTOM ORBACCENT® 35	Rounded Trapezoidal	854
TRIMDEK®	Long Length Trough	2757
SPANDEK®	Rounded Trapezoidal	698.9
KLIP-LOK® 406	Long Length Trough	4979
KLIP-LOK 700 HI-STRENGTH®	Long Length Trough	5322

a' = cross section area of water in roofing module (per valley or trough in millimeters square)

3.0 FASTENERS

When you select fasteners, you should consider the design life of the structure, because the fasteners and the cladding material should have similar life expectancies.

FASTENER CHANGE TO METRIC SIZING

The Australian fastener industry is moving to a change in fastener description that will bring it into line with international markets. This is an on-going process as product requirements and design changes.

Traditionally self drilling fasteners have been described in gauge (outside thread diameter), by tpi (threads per inch) and by length (mm). The new changes will convert gauge to metric sizing (e.g. #12 is approx. M5.5).

3.1 MATERIALS FOR SCREWS

Screws are available in a variety of materials, finishes and colours to match COLORBOND® pre-painted steel, and design. You should use screws to AS 3566.1 (or better). Additional information on fastener finishes is in the technical bulletin TB-16.

TABLE 3.1.1:

Product	Appropriate Screw Materials
For most external applications not closer than 400m from the ocean or sever marine influence:	AS 3566.1
<ul style="list-style-type: none"> COLORBOND® steel or COLORBOND® Metallic steel ZINCALUME® steel AM125 	
For severe exposure conditions:	AS 3566.1
<ul style="list-style-type: none"> COLORBOND® steel (200m to 400m from marine environments) COLORBOND® Ultra steel (100m to 200m from marine environments) AM150 	Where the colour match of fasteners is an overriding consideration, powder coated/painted fasteners may be used
For very severe exposure conditions:	Stainless steel
<ul style="list-style-type: none"> SUPERDURA® Stainless steel 	

Stainless steel fasteners are recommended for use only with COLORBOND® Stainless steel.

3.2 MATERIALS FOR NAILS

Nails should be of galvanised steel. They are only used to fix the clips of some concealed-fixed cladding to timber supports.

3.3 MATERIALS FOR BLIND RIVETS

For SUPERDURA® Stainless steel use stainless steel blind rivets with stainless steel mandrels; for GALVABOND® steel, ZINCALUME® steel and COLORBOND® steel, use aluminium blind rivets. Blind rivets are used for fixing flashings, accessories and side-laps.

3.4 MATERIALS FOR SEALING WASHERS

Sealing washers used under the heads of screws on COLORBOND® steel finishes must be made from materials that don't have significant levels of conductive carbon black, particularly in marine environments. Use EPDM washers, not neoprene.

3.5 IDENTIFICATION OF SCREWS

The format of the number code is:

12	–	14	x	50
M6	–	11	x	50
Screw gauge (Thread outside diameter)		Thread pitch (threads per inch)		Overall length of the screw measured from under the head to the tip of the drill point (mm)
M refers to metric size				

Fasteners must have a coating system to meet AS 3566.1 or AS 3566.1.

Ripple Teks®, AutoTeks®, Teks®, Designer Heads® and Zips® are registered trademarks of ITW Buildex and are recommended for specific applications. Vortex® is a registered trademark of Bremick and is recommended for specific applications. Other equivalent quality fasteners which comply to the above standards are also recommended for use with LYSAGHT® roofing and walling products.

Where a screw penetrates roof sheeting (for fixing or stitching), a sealing washer is recommended. The sealing washer is to be an EPDM non-conductive rubber.

Where a screw penetrates the rib of the sheeting (as for roofing), the 'top thread section' feature is recommended to maximise resistance to water penetration.

FIGURE 3.5.1: TYPICAL ROOFING SCREWS

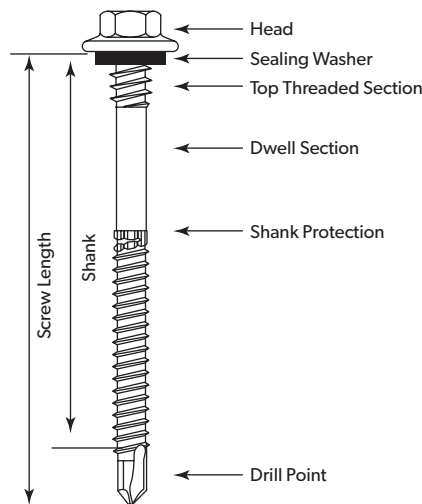

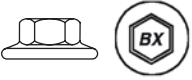







TABLE 3.5.1:

TYPICAL FEATURES OF SCREWS

Head		Shank	Drill Point
Hexagon head with integrated metal washer	Hex. head with EPDM seal	Top Tread Section Extrudes sheeting towards the seal to maximise resistance to water penetration. Grips the sheeting for a secure connection. Stops sheeting from moving when walked on.	Self drilling for metal RoofZip® Point
			
Hexagon head with integrated metal washer	Hex. head with no seal	Dwell Section Prevents the sheeting from riding up during fixing and minimises distortion of the profile.	Self drilling for timber Drill Point. Type 17
			
Wafer Head	Wafer head with no seal	Shank Protection Enlarges the hole in the sheeting to minimise damage to the protective coating on the screw.	Self drilling for metal Drill Point. Standard Metal
			
			Self drilling for metal Extended Drill Point
			
Special Self-sealing Head	RippleZips® screw head with self-sealing head		Self drilling for metal RippleZip® Point
			

3.6 SETTING OF SCREWS

Fasteners with sealing washers should be tightened only until the washer is gripped firmly enough to provide a weathertight seal. The fasteners should not be over-tightened because this may split the sealing washer or deform the sheet, either of which could lead to water penetration. Take particular care when valley fixing because there is no flexibility with the sheet hard against its support. Take particular care to ensure the fastener is driven perpendicular to the sheeting to avoid deformation of the washer.

FIGURE 3.6.1:

It is important that you set screws correctly.



3.7 QUANTITY OF FASTENERS AND CLIPS

KLIP-LOK® 406, KLIP-LOK 700 HI-STRENGTH® AND KLIP-LOK CLASSIC® 700

For number of clips, see equation at right.

For KLIP-LOK® 406, there are 2 fasteners per clip.

For KLIP-LOK 700 HI-STRENGTH® and KLIP-LOK CLASSIC® 700 there are 3 fasteners per clip.

PIERCE-FIXED PROFILES

For number of fasteners, see equation at right (n is the number of fasteners per support, as shown in the diagrams for each cladding product).

SIDE-LAPS

Side-lap fasteners are often placed at about 900mm centres. (See section 8.5).

3.8 RECOMMENDED FASTENERS AND LOCATIONS

The recommended fasteners and minimum specifications for a cladding are detailed in the individual cladding brochure. The location of the fasteners are detailed in the following diagrams for each cladding product.

FASTENER LENGTH WITH INSULATION, BOARDS AND PACKERS

Where insulation (blankets or boards, foam packers or any other packer/board where the cladding screw penetrates through the support) is installed under cladding, you may need to increase the length of screws, depending on the density and thickness of the insulation, board or packer. When the screw is properly tightened (Section 3.6):

- **into metal:** The screw manufacturer's recommendations for screw penetration should be complied with. Generally there should be at least one full thread protruding past the support you are fixing. If there are three (3) threads visible (even partial threads) then the penetration requirements are met. Where rib fixing is done, then the 'shank protection' must not reach the support (Figure 3.8.1);
- **into timber:** the screw must penetrate the timber by the same amount that the recommended screw would do if there were no insulation, i.e. same embedment.
- For deep insulation, board or packer the availability of a suitable screw, with all the recommended features and minimum specifications will need to be investigated. It may be necessary to increase the screw gauge accordingly or seek advice from the screw manufacturer. Site trial of screw fixing may need to be conducted to determine the suitability of the selected screw.

FIXING TO STEEL THICKER THAN 3MM

Use appropriate self-drilling screws with an extended drill point; or pre-drill hole and seek advice from the screw manufacturer on the appropriate screw specifications.

Number of clips per job =

$(\text{Number of supports}) \times (\text{Number of sheets} + 1)$

for KLIP-LOK® 406, or

$(\text{Number of supports}) \times (\text{Number of sheets})$

for KLIP-LOK CLASSIC® 700

Number of fasteners per job =

KLIP-LOK® 406 = number of clips \times 2

KLIP-LOK 700 HI-STRENGTH® = number of clips \times 3

KLIP-LOK CLASSIC® 700 = number of clips \times 3

Number of fasteners per job (for pierced fixing) =

$n \times (\text{Number of sheets}) \times (\text{Number of supports})$

SIDE-LAP, ACCESSORY & FLASHING FASTENINGS

For MINI ORB® and PANELRIB®

- Use 3.2mm diameter aluminium sealed blind rivets

For all other products use:

- RoofZips® M6 -11 x 25 or
- M5-16 x 25 Designer Head® or
- Hex Head Metal Tek® with seal: 10-16 x 16; or
- Sealed blind rivets: 4.8mm diameter aluminium.

FIGURE 3.8.1:

Setting screws correctly.

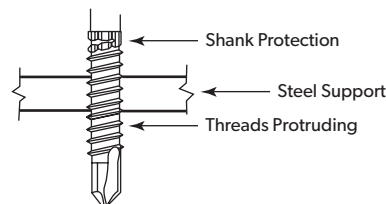

TABLE 3.8:

Guide to estimate fasteners and clips required for typical installation.

FASTENER & CLIP REQUIREMENT GUIDE (PER M²)

Cladding Profile	No. of fasteners (clips) per sheet width	Sheet Cover Width	Maximum Support Spacings (mm)					
			450*	600*	900	1200	1500	1800
CUSTOM ORB®	3	762	9	7	5	4	3	3
	5	762	15	11	8	6	5	4
CUSTOM BLUE ORB®	3	762	9	7	5	4	3	3
	5	762	15	11	8	6	5	4
CUSTOM ORB ACCENT® 21	3	762	9	7	5	4	3	3
CUSTOM ORB ACCENT® 35	3 (6 @ ends)	724	12	9	6	5	4	3
KLIP-LOK® 406	2 (1 clip)	406	-	-	6	5	4	3
		406	-	-	3	2	2	1
KLIP-LOK 700 HI-STRENGTH®	3 (1 clip)	700	-	-	2	1	1	1
		700	-	-	5	4	3	3
KLIP-LOK CLASSIC® 700	3 (1 clip)	700	-	-	2	1	1	1
		700	-	-	4	3	2	2
MINI ORB®	6	820	17	13	9	7	5	5
	11	820	30	22	15	11	9	7
MULTICLAD®	4	840	11	8	6	4	4	3
PANELRIB®	4	850	11	8	6	4	4	3
	8	850	21	16	10	8	6	5
SPANDEK®	3	700	10	8	5	4	3	3
	4	700	13	10	6	5	4	3
TRIMDEK®	4	762	12	9	6	5	4	3
TRIMWALL®	4	762	12	9	6	5	4	3
WALLCLAD®	3	762	9	7	5	4	3	3
	5	762	15	11	8	6	5	4

* Typical residential framing spacings.

TABLE 3.8.1:

Guide to fastener layout and sheet coverage.

CUSTOM ORB® & CUSTOM BLUE ORB®

SHEET COVERAGE

Width of Roof (m)	3	4	5	6	7	8	9	10	11	12	13	14	15	16	17	18	19	20	30	40	50
Number of Sheets	4	6	7	8	10	11	12	14	15	16	18	19	20	21	23	24	25	27	40	53	66

Crest: 3 fasteners †



Pan/Valley: 3 fasteners †



Crest: 5 fasteners †



Pan/Valley: 5 fasteners †



WIDTH COVERED BY 'X' NUMBERS OF SHEETS (M)

Number of Sheets	3	4	5	6	7	8	9	10	11	12	13	14	15	16	17	18	19	20
Coverage (m)	2.3	3.0	3.8	4.6	5.3	6.1	6.9	7.6	8.4	9.1	9.9	10.7	11.4	12.2	13.0	13.7	14.5	15.2

CUSTOM ORB ACCENT® 21

WIDTH COVERED BY 'X' NUMBERS OF SHEETS (M)

Number of Sheets	3	4	5	6	7	8	9	10	11	12	13	14	15	16	17	18	19	20
Coverage (m)	2.3	3.0	3.8	4.6	5.3	6.1	6.9	7.6	8.4	9.1	9.9	10.7	11.4	12.2	13.0	13.7	14.5	15.2

Crest: 3 fasteners †



Valley: 3 fasteners †



CUSTOM ORB ACCENT® 35

SHEET COVERAGE

Width of Roof (m)	3	4	5	6	7	8	9	10	11	12	13	14	15	16	17	18	19	20	30	40	50
Number of Sheets	5	6	7	9	10	11	13	14	15	17	18	20	21	22	24	25	26	28	41	55	69

Crest: 3 fasteners per sheet for internal supports



Crest: 6 fasteners per sheet for end supports (including single spans)



Valley: 3 fasteners per sheet for internal and end supports



Valley: 6 fasteners per sheet for end supports (including single spans)



WIDTH COVERED BY 'X' NUMBERS OF SHEETS (M)

Number of Sheets	3	4	5	6	7	8	9	10	11	12	13	14	15	16	17	18	19	20
Coverage (m)	2.2	2.9	3.6	4.3	5.1	5.8	6.5	7.2	8.0	8.7	9.4	10.1	10.9	11.6	12.3	13.0	13.8	14.5

† Fasteners per sheet per support.

KLIP-LOK 700 HI-STRENGTH® & KLIP-LOK CLASSIC® 700

SHEET COVERAGE

Width of Roof (m)	3	4	5	6	7	8	9	10	11	12	13	14	15	16	17	18	19	20	30	40	50
Number of Sheets	5	6	8	9	10	12	13	15	16	18	19	20	22	23	25	26	28	29	43	58	72

KLIP-LOK 700 HI-STRENGTH®

1 clip and 3 fasteners †

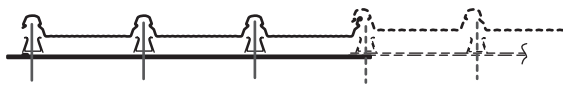

KLIP-LOK CLASSIC® 700

1 clip and 3 fasteners †

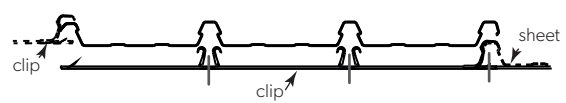

WIDTH COVERED BY 'X' NUMBERS OF SHEETS (M)

Number of Sheets	3	4	5	6	7	8	9	10	11	12	13	14	15	16	17	18	19	20
Coverage (m)	2.1	2.8	3.5	4.2	4.9	5.6	6.3	7.0	7.7	8.4	9.1	9.8	10.5	11.2	11.9	12.6	13.3	14.0

KLIP-LOK® 406

SHEET COVERAGE

Width of Roof (m)	3	4	5	6	7	8	9	10	11	12	13	14	15	16	17	18	19	20	30	40	50
Number of Sheets	8	10	13	15	18	20	23	25	28	30	33	35	37	40	42	45	47	50	74	99	124

1 clip, 2 fasteners †

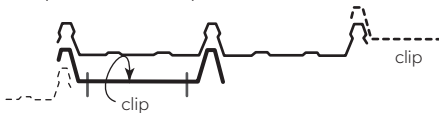

WIDTH COVERED BY 'X' NUMBERS OF SHEETS (M)

Number of Sheets	3	4	5	6	7	8	9	10	11	12	13	14	15	16	17	18	19	20
Coverage (m)	1.2	1.6	2.0	2.4	2.8	3.2	3.7	4.1	4.5	4.9	5.3	5.7	6.1	6.5	6.9	7.3	7.7	8.1

MINI ORB®

SHEET COVERAGE

Width of Wall (m)	3	4	5	6	7	8	9	10	11	12	13	14	15	16	17	18	19	20	30	40	50
Number of Sheets	4	5	7	8	9	10	11	13	14	15	16	18	19	20	21	22	24	25	37	49	61

Pan/Valley: 6 fasteners †



Pan/Valley: 11 fasteners †



WIDTH COVERED BY 'X' NUMBERS OF SHEETS (M)

Number of Sheets	3	4	5	6	7	8	9	10	11	12	13	14	15	16	17	18	19	20
Coverage (m)	2.5	3.3	4.1	4.9	5.7	6.6	7.4	8.2	9.0	9.8	10.7	11.5	12.3	13.1	13.9	14.8	15.6	16.4

MULTICLAD®

SHEET COVERAGE

Width of Wall (m)	3	4	5	6	7	8	9	10	11	12	13	14	15	16	17	18	19	20	30	40	50
Number of Sheets	4	5	6	8	9	10	11	12	14	15	16	17	18	20	21	22	23	24	36	48	60

Pan/Valley: 4 fasteners †



WIDTH COVERED BY 'X' NUMBERS OF SHEETS (M)

Number of Sheets	3	4	5	6	7	8	9	10	11	12	13	14	15	16	17	18	19	20
Coverage (m)	2.5	3.4	4.2	5.0	5.9	6.7	7.6	8.4	9.2	10.1	10.9	11.8	12.6	13.4	14.3	15.1	16.0	16.8

† Fasteners per sheet per support.

TABLE 3.8.1 (CONTINUED):

Guide to fastener layout and sheet coverage.

PANELRIB®

SHEET COVERAGE

Width of Wall (m)	3	4	5	6	7	8	9	10	11	12	13	14	15	16	17	18	19	20	30	40	50
Number of Sheets	4	5	6	8	9	10	11	12	13	15	16	17	18	19	20	22	23	24	36	48	59

Pan: 4 fasteners †



Pan: 8 fasteners †



WIDTH COVERED BY 'X' NUMBERS OF SHEETS (M)

Number of Sheets	3	4	5	6	7	8	9	10	11	12	13	14	15	16	17	18	19	20
Coverage (m)	2.6	3.4	4.3	5.1	6.0	6.8	7.7	8.5	9.4	10.2	11.1	11.9	12.8	13.6	14.5	15.3	16.2	17.0

SPANDEK®

SHEET COVERAGE

Width of Roof (m)	3	4	5	6	7	8	9	10	11	12	13	14	15	16	17	18	19	20	30	40	50
Number of Sheets	5	6	8	9	10	12	13	15	16	18	19	20	22	23	25	26	28	29	43	58	72

Crest: 3 fasteners †



Crest: 4 fasteners †

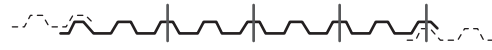

Pan/Valley: 3 fasteners †

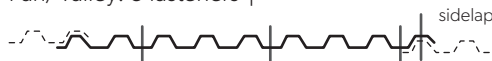

Pan/Valley: 4 fasteners †

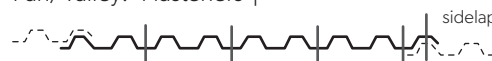

WIDTH COVERED BY 'X' NUMBERS OF SHEETS (M)

Number of Sheets	3	4	5	6	7	8	9	10	11	12	13	14	15	16	17	18	19	20
Coverage (m)	2.1	2.8	3.5	4.2	4.9	5.6	6.3	7.0	7.7	8.4	9.1	9.8	10.5	11.2	11.9	12.6	13.3	14.0

TRIMDEK® & TRIMWALL® - (TRIMWALL® PAN FASTEN ONLY)

SHEET COVERAGE

Width of Roof (m)	3	4	5	6	7	8	9	10	11	12	13	14	15	16	17	18	19	20	30	40	50
Number of Sheets	4	6	7	8	10	11	12	14	15	16	18	19	20	21	23	24	25	27	40	53	66

Crest: 4 fasteners †



Pan/Valley: 4 fasteners †

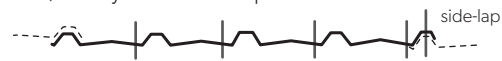

WIDTH COVERED BY 'X' NUMBERS OF SHEETS (M)

Number of Sheets	3	4	5	6	7	8	9	10	11	12	13	14	15	16	17	18	19	20
Coverage (m)	2.3	3.0	3.8	4.6	5.3	6.1	6.9	7.6	8.4	9.1	9.9	10.7	11.4	12.2	13.0	13.7	14.5	15.2

WALLCLAD® - (VALLEY/PAN FASTEN ONLY)

SHEET COVERAGE

Width of Wall (m)	3	4	5	6	7	8	9	10	11	12	13	14	15	16	17	18	19	20	30	40	50
Number of Sheets	4	6	7	8	10	11	12	14	15	16	18	19	20	21	23	24	25	27	40	53	66

Valley Fixed - All fixing as specified for CUSTOM ORB®

Pan/Valley: 3 fasteners †

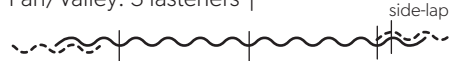

Pan/Valley: 5 fasteners †



WIDTH COVERED BY 'X' NUMBERS OF SHEETS (M)

Number of Sheets	3	4	5	6	7	8	9	10	11	12	13	14	15	16	17	18	19	20
Coverage (m)	2.3	3.0	3.8	4.6	5.3	6.1	6.9	7.6	8.4	9.1	9.9	10.7	11.4	12.2	13.0	13.7	14.5	15.2

† Fasteners per sheet per support.

4.0 CURVED, BENT & TAPERED CLADDING

Curved sheets can be used for both roofing and walling applications. Sheeting can be curved into either concave or convex shapes as required.

An excellent method of cladding low-slope gable roofs is to run continuous lengths of roofing from eave to eave, across the full width of the roof. This gives a particularly neat and attractive roof. It is also possible to spring-curve sheets into a concave shape.

With the exception of KLIP-LOK®, the ridge capping is eliminated in these roofs, thus avoiding any possibility of leakage along the ridge. KLIP-LOK® can be used similarly, but the ribs are cut at the ridge and a metal cap is fitted over the cut.

4.1 SPRING-CURVED-RIDGE ROOF

Sheets in a spring-curved-ridge roof remain straight except for a curve near the ridge.

Only the sheet profiles recommended for spring-curving are shown in Table 4.1.1.

Over the supports at the ridge, very slight crease marks may appear in the pans or valleys when subjected to foot traffic. They don't affect strength and will usually not be seen from the ground.

Each sheet is first fixed to one side of the roof, and then pulled down to be fixed to the other side. To minimise small laying errors, lay alternate sheets from opposite sides of the roof.

Side-laps should be sealed with silicone sealant for the length of the curve.

Although not recommended the industry has spring curved wide-panned profiles. The pans of KLIP-LOK® and TRIMDEK® tend to oilcan (minor waviness in the pan) when spring curved.

Apart from not looking good, an oil canned pan may retain water which could lead to discolouration and/or deterioration of the sheet coating and also contributes to thermally induced roof noise. In some projects oil-canning in the pans has been acceptable.

These profiles have been spring-curved up to a maximum slope of 1 in 30 (2°); with the spacing between the purlins at the ridge being slightly less than the internal span recommended for the profile in Table 2.12.1.

FIGURE 4.1:

Typical curved and bent applications.

Spring-curved-ridge roof

Sheets straight except for a curve near the ridge.



Spring-arched or convex roof

Sheets curved in a radius from eave to eave.



Spring-curved concave roof

Sheets curved concavely in a radius.



Pre-curved sheets

Sheets curved by machine before installation.



Capped bent ribbed roofs

(for example KLIP-LOK®).



FIGURE 4.1.1:

Spring-curved-ridge roof.

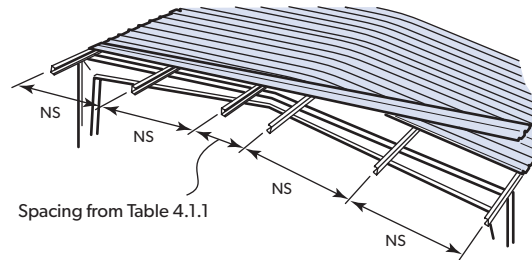

Spacing from Table 4.1.1

Spacing definitions

NS = Normal spacing given in Table 2.3.1

TABLE 4.1.1:

Minimum spacing of purlins at ridge for spring-curved-ridge roof (mm).

	BMT	1 in 20 (3°)	1 in 15 (4°)	1 in 12 (5°)	1 in 10 (6°)	1 in 8 (7°)
SPANDEK®	0.42	1400	1500			
	0.48	1500	1600	1700		
CUSTOM ORB ACCENT® 21	0.48	1250				
CUSTOM ORB®	0.42			1200		
	0.48			1300	1400	
CUSTOM BLUE ORB®	0.60			1200	1300	1400

Note: Blank spaces are combinations not recommended.

4.2 SPRING-ARCHED ROOF

Sheets in a spring-arched (convex) roof are curved in a radius from eave to eave. SPANDEK®, CUSTOM ORB ACCENT®, CUSTOM ORB® and CUSTOM BLUE ORB® can be spring-curved for an arched roof. Table 4.2.1 shows the acceptable radii.

The top face of all purlins must accurately follow and be tangential to the radius of the arch. The radius of curvature can be calculated from the formula in Figure 4.2.1.

At the crest of an arch the roof is flat, which is obviously below the specified minimum roof pitch. Therefore side-laps of shallow roof profile as such as CUSTOM ORB®, CUSTOM ORB ACCENT®, CUSTOM BLUE ORB® and SPANDEK® should be sealed over the crest of the arch until there is sufficient pitch to give adequate drainage (see Table 2.12.1). The length of seal is shown in Figure 4.2.2. Refer to Section 7.9 for sealant application.

Over the supports very slight lip wave or slight crease marks may appear in the pans or valleys when subjected to foot traffic or at minimum radius. They don't affect strength and will usually not be seen from the ground.

If end-laps are necessary they should not be located at or near the crest of the arch and each sheet length must span at least three purlin spacings.

Refer to Section 8.5 for side-lap fixing.

Profiles with wide pans manufactured from high tensile steel (such as KLIP-LOK® and TRIMDEK®) are susceptible to local buckling of the pans and are therefore not recommended for spring-arched roofs. Some of these products may be available in soft steel (G300) to minimise this problem, however the availability would be only on special projects (high profile and large volume) and subject to special commercial arrangements (pricing, MOQ lead times, toll-rolling, testing, etc.).

Each sheet is first fixed to one side of the roof, and then pulled down to be fixed to the other side. Alternate sheets are laid from opposite sides of the roof.

FIGURE 4.2.1:

Calculation of radius.

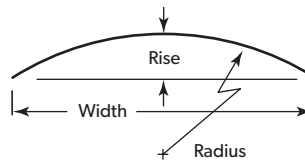

$$\text{Radius} = \frac{\text{Width}^2 + 4 (\text{Rise})^2}{8 \times \text{Rise}}$$

FIGURE 4.2.2:

Seal length for side-laps on spring-arched roof.

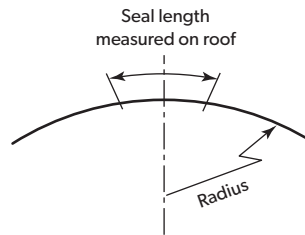

Seal Length

CUSTOM ORB® and CUSTOM BLUE ORB® (minimum roof pitch 5°) = 0.175 x radius

CUSTOM ORB ACCENT® 35 (minimum roof pitch 2°) = 0.105 x radius

CUSTOM ORB ACCENT® 21 (minimum roof pitch 3°) = 0.158 x radius

SPANDEK® (minimum roof pitch 3°) = 0.105 x radius

TABLE 4.2.1:

Recommended radii for convex spring-curving.

	BMT	Minimum Radius (m)	Purlin Spacing at minimum radius (mm)	Maximum radius ⁽¹⁾ (m)
SPANDEK®	0.42	20	1200	60
	0.48	20	1400	60
CUSTOM ORB ACCENT® 21	0.40	18	900	40
	0.48	15 ⁽²⁾	900	40
CUSTOM ORB ACCENT® 35	0.48	50	900*/1200†	60
CUSTOM ORB®	0.42	12	800	35
	0.48	10	1000	35
CUSTOM BLUE ORB®	0.60	9	900	35

⁽¹⁾ Maximum radius is to provide sufficient drainage near crest of arch.

⁽²⁾ Every 2nd rib at ends must be fixed.

* For end span. † For interior span.

4.3 SPRING-CURVED CONCAVE ROOFS

Roofing can be spring-curved into concave shapes. Table 4.3.1 shows the acceptable radii.

FIGURE 4.3.1:

Spring-curved concave roof.

Roof pitch at the lower end of the sheeting must not be less than the minimum shown in Table 2.12.1.

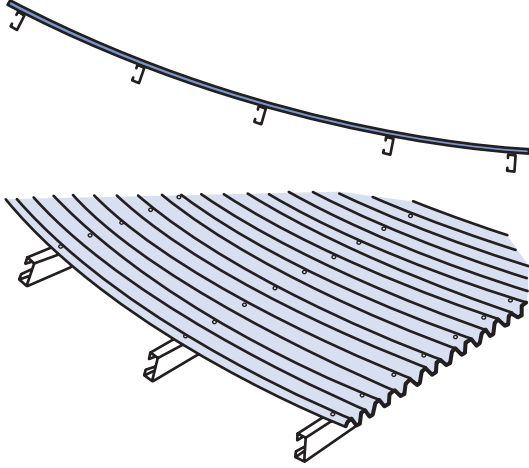

TABLE 4.3.1:

Radii for spring curved concave roofs.

	BMT	Minimum Radius (m)	Purlin Spacing (mm)
KLIP-LOK® 406	0.48	26	1400
SPANDEK®	0.42	18	1200
	0.48	20	1400
TRIMDEK®	0.42	20	1000
	0.48	22	1200
CUSTOM ORB®	0.42	10	800
	0.48	10	1000
CUSTOM BLUE ORB®	0.60	8	800
CUSTOM ORB ACCENT® 21	0.40	18	900
	0.48	18	900
		15	1200
CUSTOM ORB ACCENT® 35	0.48	40	900*
			1200†

The purlin spacing may be increased for radii greater than the minimum radii shown, provided the spacing does not exceed that shown in Table 2.12.1.

* For end spans. † For interior spans.

Over the supports very slight lip wave or slight crease marks may appear in the pans or valleys when subjected to foot traffic or at minimum radius. They don't affect strength and will usually not be seen from the ground.

Refer to Section 8.5 for side-lap fixing.

4.4 PRE-CURVED SHEETS

Pre-curving of CUSTOM BLUE ORB® and MINI ORB® is available for various applications - we don't recommend pre-curving for other profiles.

Pre-curved corrugated roofing is popular for aesthetics (such as a bullnosed verandah roof), or for function (such as a gutterless eave design). CUSTOM BLUE ORB® can be curved to a small radius (300mm to 400mm - local variations apply).

MINI ORB® can be curved to a radius to as small as 150mm, though it isn't recommended for roofing.

Because of the spacing of curving rolls, there is usually a straight portion at the end of the sheet beyond the curve (often 50 to 110mm for CUSTOM BLUE ORB®, and about 50mm for MINI ORB®). Allow for this in your design. It can be trimmed off if necessary.

If a pre-curved section of cladding is to be joined to a straight section, it is recommended that you order the curved and straight sheets at the same time, asking for them to be matched in production to ensure a quality end-lap. End-lap the sheets as described in Section 10.4 (End-lapping).

Our CUSTOM BLUE ORB® and the MINI ORB® pages of the LYSAGHT® Walling Products brochure gives more details on curving.

4.5 CAPPED BENT RIBBED ROOFS

Tray cladding can be used in continuous lengths from eave to eave by cutting the ribs and bending the pans at the ridgeline. The same process is used on Mansard roofs. Caps are fitted over the cut ribs, which open up when the pans are bent. Fitting the rib caps can be time-consuming and care must be taken with sealing to avoid any possibility of leakage.

The ribs must be cut squarely, with a metal cutting blade in a power saw, set to the depth of the rib minus 2mm.

In some states pressed steel caps may be available to suit KLIP-LOK® ribs, though the range of angles is limited. Caps can be handmade to suit any angle from flat sheet.

KLIP-LOK® is most frequently used for capped bent ribbed roofs, but LONGLINE 305®, TRIMDEK® or even SPANDEK® can be used. For these four profiles the rib caps can be made from pieces of rib profile cut from a short length of cladding. A neutral-cure silicon sealant should be used.

FIGURE 4.5.1:

Capped bent ribbed roof.

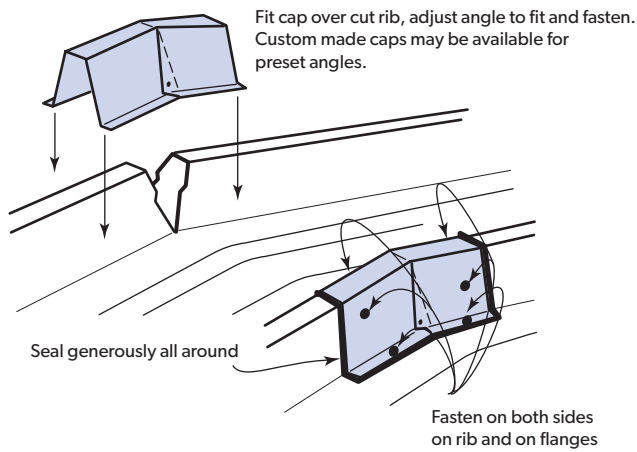

5.0 INSULATION & SKYLIGHTS

You often consider insulating a building to reduce:

- heating from the sun in summer;
- loss of heat from inside in winter;
- condensation on the inside of the roofing and walling; and
- noise from rain, thermal expansion and contraction, and other sources.

Usually, when one of these four is treated, there is also a beneficial effect on the others.

You need to compare the initial cost of installing insulation with the savings in costs of heating and cooling. There are also gains for the environment when you save energy.

5.1 HEAT CONTROL

In summer buildings get hot from the sun and we want to cool the inside; in winter we often heat the inside and want to avoid losing that heat.

Factors in controlling heat include:

- the orientation of the building relative to the sun;
- external shading from trees or other buildings;
- design of the building, especially ventilation and sealing at doors and windows;
- the colours and surface gloss of the cladding.

The first three factors are outside the scope of this book. Heat is absorbed into a sheet on one side, and some of that absorbed heat is re-radiated from the other side (Figure 5.1.1).

- Light-coloured or shiny surfaces don't absorb much heat, and they radiate little.
- Dark-coloured or dull surfaces absorb a lot of heat, and they radiate a lot. This doesn't stop you using darker claddings because you can use reflective foil laminate under the cladding.

COLORBOND® STEEL WITH THERMATECH® TECHNOLOGY

COLORBOND® steel's core colour range in the Classic and Matt finish features our specially designed Thermatech® solar reflectance technology. Thermatech® reflects more of the sun's heat on hot, sunny days which may help increase your comfort while reducing your dependence on air conditioning. Thermatech® is available in all core colours except Night Sky®.

COMPARISON OF THERMAL PERFORMANCE

Table 5.1.1 shows thermal performances of different insulation systems by showing the heat that may be expected through roofs of new materials.

FIGURE 5.1.1:

Heat transmitted into a building.

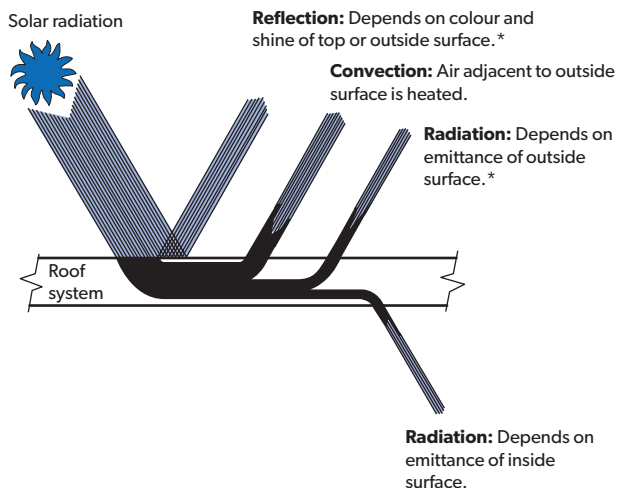

* A light shiny surface has high reflection and low emittance. A dark dull surface has low reflection and high emittance.

HEAT CONTROL METHODS

In roofs, a simple, inexpensive and very effective method is to drape a membrane of reflective foil laminate over the supports before laying the cladding. The laminate can also provide a vapour barrier to minimise condensation. If the membrane is allowed to drape 50 to 75mm between the supports the air space between the membrane and the roof cladding will further improve heat insulation (Figure 5.1.2).

Additional heat insulation is often achieved by using bulk insulation blankets or batts (Figure 5.1.3).

The same principles apply to walls, though the foil is not draped.

FIGURE 5.1.2:

Reflective foil laminate is simple, cheap and very effective.

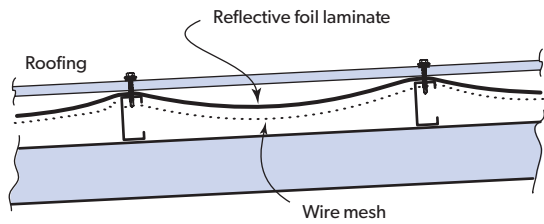

FIGURE 5.1.3:

Typical roof insulation with foil and blanket.

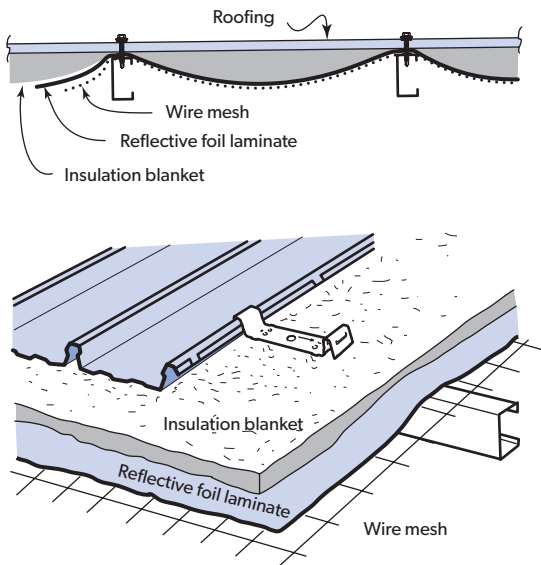

TABLE 5.1.1:

Approximate thermal transmission (for comparisons only).

	Roofing only		Roofing with reflective foil laminate		Roofing with 50mm insulation blanket & reflective foil laminate	
	Heat radiated from underside	Heat radiated + convected	Heat radiated from underside	Heat radiated + convected	Heat radiated from underside	Heat radiated + convected
	W/m ²	W/m ²	W/m ²	W/m ²	W/m ²	W/m ²
ZINCALUME® steel	25	40	2.0	9.0	2.0	7.0
COLORBOND® steel						
COOLMAX® (WHITEHAVEN®)	22.5	26.6	0.9	3.8	0.6	2.7
CLASSIC CREAM™, SURFMIST®	37.1	43.8	1.5	6.1	1.1	4.3
SANDBANK®	59.7	70.3	2.4	9.6	1.7	6.9
WILDERNESS®	91.2	106.9	3.6	14.4	2.5	10.3
WOODLAND GREY®	101.4	118.7	4.0	15.9	2.8	11.3
DEEP OCEAN®	108.2	126.6	4.3	16.9	3.0	12.0

Assumptions:

Solar radiation = 850 W/m² (average Australian summer), Ambient temperature = 30°C, Wind velocity over rood = 3m/s, Still air under the roof system, Inside temperature = 30°C.

5.2 CONDENSATION

When the air in a building in contact with metal cladding is warmer than the cladding, water vapour (moisture) in the air can condense on the inside of the cladding.

Water vapour passes fairly freely through most building linings into the ceiling and wall spaces where it may directly contact the cladding.

Condensation can lead to deterioration of building components and staining of ceiling and walls. If insulation blankets or batts are wet, or even slightly dampened by condensation, its efficiency is reduced markedly.

The amount of condensation depends upon the amount of water vapour in the air and this varies with climatic conditions. Activities within a building can add substantially to the amount of water vapour, and typical domestic situations include bathing, showering, cooking, washing and drying clothes and dishes, and breathing. It is essential to vent substantial amounts of water vapour to outside the building.

To minimise the risk of condensation on the underside of roofing, a vapour barrier is often used to prevent contact of warm moist air with the roofing – reflective foil laminate is commonly used.

To minimise the risk of condensation on the underside of the laminate, the laminate must be draped between roof supports so that the cold cladding is not in contact with the laminate (except at the supports).

5.3 NOISE REDUCTION

Noise in metal roofing can result from many factors or a mix of factors. Factors that could result in metal roofing noise are thermal effects; rain; wind action; weather extremes such as hail, thunder; structural movements resulting from lack of rigidity, ground movement, structural settlement, shrinkage, ground movements or excavations; access from animals and vermins (such as possum); falling debris such as tree matter; vibration from passing vehicles, aircraft, nearby equipment; etc. The type of noise, frequency, patterns, volume, duration and regularity can be quite variable.

It is the designer's responsibility to identify potential cause(s) of noise and then incorporate within the roof design suitable details to minimise the potential or severity of noise.

Below are two common types of noise.

RAIN NOISE

To reduce rain noise on metal roofing, an insulation blanket can be placed over the foil laminate described above, before laying the roofing. It is important that the laminate is pulled tight enough to hold the blanket hard against the underside of the roofing so as to dampen the rain-induced vibration at the point of impact. If the blanket is not hard against the roofing the noise reduction will not be as good.

For purlin spacings over 1200mm: first lay wire mesh over the purlins, tighten and fix it, before laying the membrane.

THERMALLY-INDUCED NOISE

Roofing expands and contracts due to temperature changes in the cladding, and particularly rapid changes can be caused by passing clouds or a strong breeze. For example: if a passing cloud suddenly shades the roof from the sun, the cladding temperature could drop about 3°C after 30 seconds in shade and about 10°C after 2 minutes in shade.

Thermally-induced noise is caused by slipping at fasteners/connection where the roof expands relative to its supports/clips. The slipping is controlled by the friction between the roof and its supports/clips. When the static friction is overcome impulsively, sounds are produced — the higher the friction, the louder the sound. No damage to the cladding or fasteners will occur. The sounds produced can be variable from crackling noises, banging noises, clicking noise to loud pistol shots, and the patterns and continuity of the sounds can vary.

The noise can be reduced by a range of methods, depending upon the type of roofing. As a guide some of methods may include:

- Placing a material with low coefficient of friction between the roofing and its supports (for example PVC tape or strips of foil laminate);
- Choosing steel supports rather than timber (lower coefficient of friction);
- Choosing light coloured roofing;
- Venting the roof space;
- Including an expansion joint (Section 10.5); being careful about design details in valleys (where heat tends to be retained); and/or
- Insulating the roof space to reduce the thermal differential. In tropical areas it may be better to insulate the ceiling rather than the roofing (which can also reduce noise) by having the silver foil facing upwards towards the roofing, instead of downwards towards the ceiling;
- Insulation pulled tight enough to hold the blanket hard against the underside of the roofing so as to dampen the noise
- For clip-fixed roofing the spacing of the supports should be maximised. This is particularly important for the high performance clip-fixed roofing with preference for the support spacing to be 1500mm or greater

- Ensure that the structure is rigid and well braced to minimise movements resulting from such things such as vibrations, wind or thermal action.

5.4 INSULATION MATERIALS

Typical insulation materials are reflective foil laminates, insulation blankets or batts made from fibreglass, and boards made from polystyrene. Remember that the colour of cladding also has a marked effect (Section 5.1).

FOIL LAMINATES

Foil laminates reflect heat and can double-up as a vapour barrier to control condensation. Where they are used as a vapour barrier the joints between successive strips are overlapped about 100mm, and sealed with a tape impervious to moisture.

BLANKETS AND BATTS

Blankets and batts minimise heat convection and are available with the laminate bonded to the fibreglass. They are also effective in reducing noise.

Insulation blankets must be protected from moisture, particularly around the edges of the roof and even more particularly at the bottom end of the cladding where rainwater run-off can be blown back under a low-pitched roof. If the blanket overhangs the bottom support, it may even come into contact with water in the gutter, where the insulation will absorb moisture and remain damp for extended periods, thus leading to deterioration of the coating on the underside of the roofing and reducing the effectiveness of the insulation.

Insulation blankets up to a nominal thickness of up to 100mm for pierce-fixed cladding and KLIP-LOK 700 HI-STRENGTH®; and up to 50mm for KLIP-LOK® 406 and all other concealed-fixed profiles will compress sufficiently over the roof supports to allow normal procedures to be used for fixing.

For KLIP-LOK CLASSIC® 700, in thicknesses between 75-100mm, seek advice from our technical support line. However, you may need to increase the length of fasteners slightly to allow for the thickness of the compressed blanket between the cladding and support.

POLYSTYRENE BOARDS

Expanded and extruded polystyrene is also used for the same purposes as blankets and batts. The boards are more rigid and relatively less compressible which demand different fixing to that mentioned above. Seek advice from manufacturers of polystyrene insulation.

5.5 INSULATION THICKNESS (GLASS WOOL)

Insulation blankets and batts can cause cladding to bow out between the supports, between fasteners along the support, or bow the pans. To minimise this problem, the maximum thickness of blankets and batts or normal density should be 100mm (nominal) for pierce-fixed cladding and KLIP-LOK 700 HI-STRENGTH® and 50mm for KLIP-LOK® 406. (Maximum density 12kg/m³) For KLIP-LOK CLASSIC® 700, in thicknesses between 75-100mm (nominal), seek advice from our technical support line. For more dense glass wool and rock wool, and thicker insulation, spacers are recommended.

Furthermore the cladding can bow when the blankets or batts are placed over taught safety wire. Taught safety wire prevents the insulation from draping between supports, thus compressing the insulation between the supports. This reduces the effectiveness of the insulation and also results in greater pressure placed under the cladding. Where the safety wire is taught then spacers are recommended to minimise these issues.

5.6 SKYLIGHTING

One of the simplest methods of getting natural light through a steel roof is the inclusion of translucent sheets which match the steel profiles.

It is preferable to use profiled translucent cladding in single widths so that they can overlap, and be supported by, the steel cladding on both sides. It is also preferable to position the lengths of translucent cladding at the top of a roof run so the high end can lap under the capping or flashing and the low end can overlap a steel sheet. This is because the translucent cladding will readily overlap a steel sheet but the reverse is difficult.

Building regulations require a safety mesh to be fitted under translucent cladding.

Because of its greater thermal expansion, translucent cladding should be fixed using oversized holes and sealing washers recommended by the translucent cladding manufacturer. When used with concealed fixed claddings, ensure the fasteners do not penetrate the steel cladding. There are translucent products available that easily accommodate this and some translucent products have a clip-fixing system to allow thermal movement. Don't exceed the maximum support spacing specified by the translucent cladding manufacturer.

Skylighting increases the transmission of solar heat. Generally speaking, heat transmission is proportional to light transmission, so the more sunlight that enters a building the hotter it will be. Clear, uncoloured fibreglass has good light transmission of about 65% but this means on a typical summer day, with peak solar radiation of 850 W/m², transmission through a clear fibreglass skylight would be about 550 W/m².

Translucent fibreglass cladding is available to match CUSTOM ORB®, KLIP-LOK® 406, KLIP-LOK CLASSIC® 700, KLIP-LOK 700 HI-STRENGTH®, SPANDEK® and TRIMDEK®. Polycarbonate cladding is also available for CUSTOM ORB® and TRIMDEK®.

FIGURE 5.6.1:

Placement of translucent sheets - pierce fixed decks.

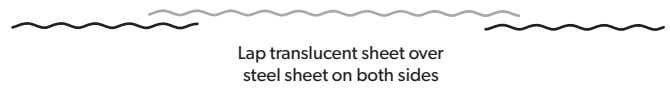
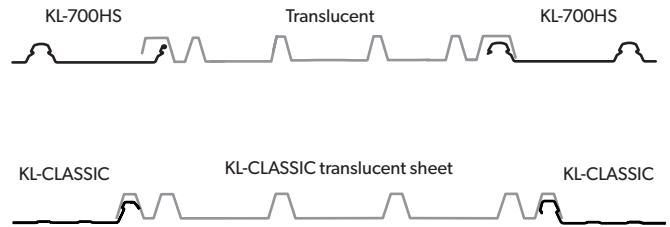
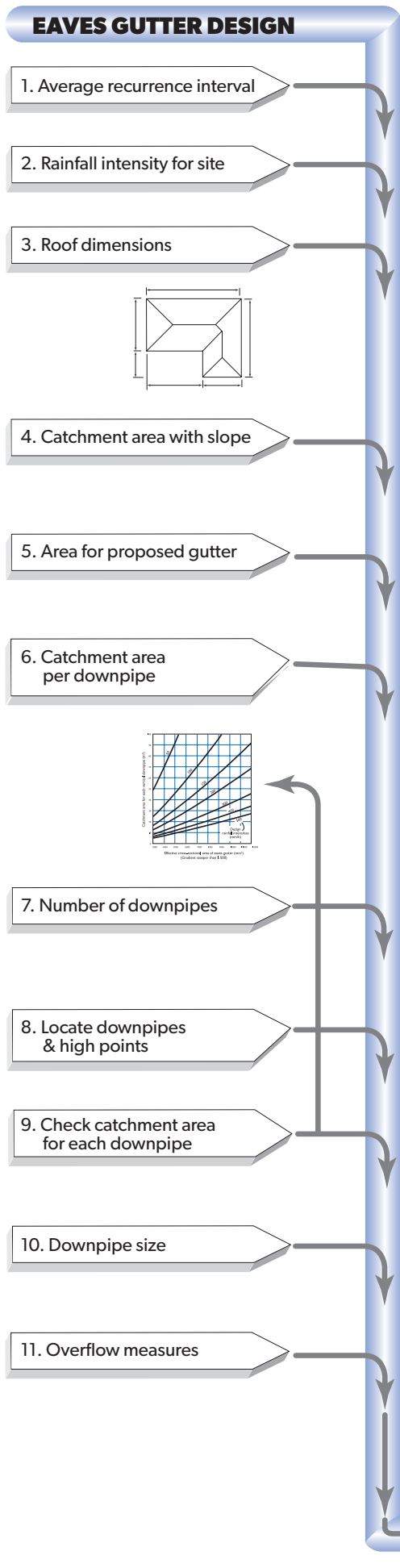

FIGURE 5.6.2:

Placement of translucent sheets - concealed fixed decks.



6.0 ROOF DRAINAGE



The following section should be considered as a guide only. For comprehensive design details refer to AS/NZS 3500.3, HB114:1998. Also more guides are in our local regional Rainwater Solutions brochures.

6.1 INTRODUCTION

Roof drainage systems can be affected by a number of variables and must be designed and detailed by a suitable qualified trade or professional. The design of roof drainage aims to protect people, property and the building. The designed drainage system must be installed under the supervision of a qualified trade or professional. The steps of the design process are illustrated below.

1. Determine average recurrence interval (ARI).
2. Obtain rainfall intensity of site.
3. Work out roof dimensions.
4. Determine catchment area with slope.
5. Determine area for proposed eaves gutter.
6. Determine catchment area per downpipe.
7. Determine number of downpipes required.
8. Determine location of downpipes and high points.
9. Check catchment area for each downpipe.
10. Determine downpipe size.
11. Determine overflow measures.

6.2 DESIGN OF DRAINAGE (EAVES-GUTTER SYSTEM)

The steps in the design process are for a perimeter drainage system using the standard roll-formed rainwater products (gutters) installed at the building eaves. Drainage systems for larger roofs use box gutters at the perimeter and internally. Box gutter systems are thoroughly treated in AS/NZS 3500.3 and HB114:1998.

In the following steps it is assumed that the eaves gutters will have a gradient of 1:500 or steeper.

1. Decide on the average recurrence interval (ARI). Where significant inconvenience or injury to people, or damage to property (including contents of a building), is unlikely (typical of an eaves-gutter system) a minimum ARI can be 20 years. If these conditions are likely (typical of box gutters) 100 years is recommended.
2. Determine rainfall intensity for the site from Table 6.2.1. More data is in AS/NZS 3500.3; NCC. or in our local regional Rainwater Solutions brochure.
3. Sketch a roof plan showing dimensions in plan view, pitch of roof, layout of ridges and valleys and large roof penetrations.
4. Calculate the catchment area of the roof from the plan. To allow for the slope of the roof, refer to AS/NZS 3500.3 for the increased area. As a "rule of thumb" allow 1% for every degree of pitch up to 36°.
5. Get the effective cross-sectional area of the gutter you intend to use from Table 6.2.2.
6. Using the cross-sectional area of the gutter on the graph in Figure 6.2.2, determine the catchment area per downpipe.

7. Calculate (as a first test) the minimum number of downpipes required for the selected gutter using the equation:

$$\left. \begin{array}{l} \text{Number of} \\ \text{downpipes (min.)} \end{array} \right\} = \frac{\text{Total catchment area of the roof}}{\text{Catchment area (determined in 6)}}$$

Round the number of downpipes up to the next whole number.

8. On the plan, select locations for the downpipes and the high points in the gutters. Where practical, the catchments for each downpipe should be about equal in area. When selecting the location of high points and downpipes, consideration should also be given to proximity to high concentrations of water flow (e.g. valley gutters, diversions around large roof penetrations, dormers, etc.) More guidance is given in AS/NZS 3500.3, HB114:1998 and NCC. Calculate the area of each catchment for each downpipe.

9. With the area of your eaves gutter, check that the catchment area for each downpipe, calculated in Step 8, is equal to or less than the catchment area shown by the graph.

If a catchment area is too big then you can:

- Increase the number of downpipes;
- Reposition the downpipes and/or the high points;
- Choose a gutter with bigger effective cross-sectional area, & repeat the above from Step 6.

10. Decide on the downpipe size. Recommendations in AS/NZS 3500.3 on downpipe sizes.

11. Consider measures to counter overflow of gutters into the building. Consideration of overflow at high concentrations of water flow may need to be given.

Install gutters with a suitable fall to avoid ponding and to allow water to easily flow away. Steeper falls are preferred for prolonged life of the gutter.

TABLE 6.2.1:

Design rainfall intensities.

	ARI once in 20 years mm/hr	ARI once in 100 years mm/hr
ACT		
Canberra	143	193
New South Wales		
Broken Hill	143	219
Sydney	200	262
Newcastle	226	316
Victoria		
Mildura	142	218
Melbourne	132	187
Ballarat	131	188
Queensland		
Brisbane	234	305
Rockhampton	229	300
Mackay	250	316
Mt. Isa	199	260
Townsville	235	300
Cairns	229	278
South Australia		
Mount Gambier	103	144
Adelaide	124	184
Western Australia		
Geraldton	138	193
Perth	130	172
Tasmania		
Hobart	85	116
Northern Territory		
Alice Springs	166	239
Darwin	233	274

Extract from NCC

FIGURE 6.1.1:

Typical gutters.

Eaves Gutters



Box Gutter

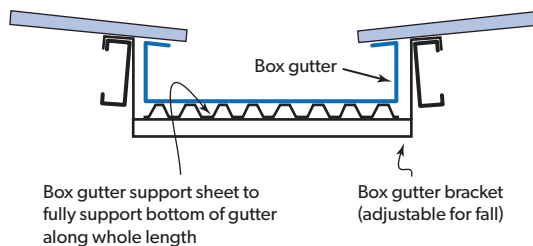
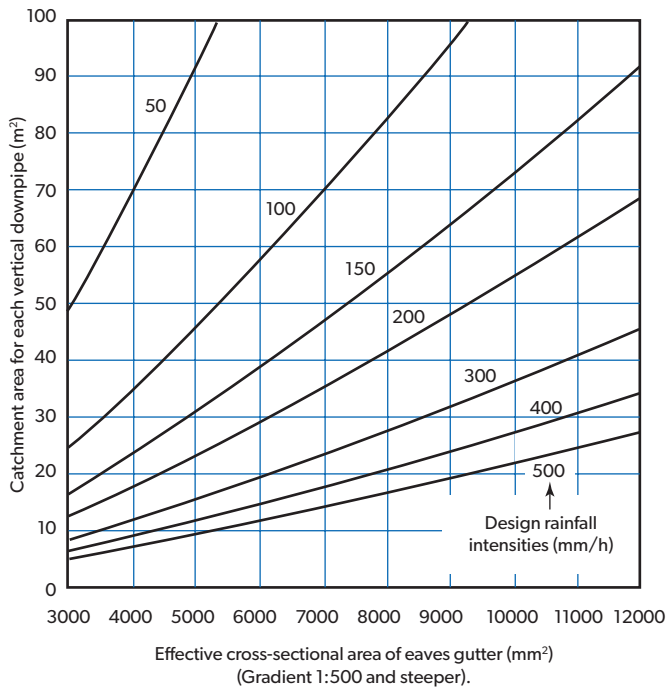

FIGURE 6.2.2:

Cross-sectional area of eaves gutters required for various roof catchment areas (where gradient of gutter is 1:500 and steeper). (Adapted from AS/NZS 3500.3).



EXAMPLE

Find the catchment area for each downpipe on a house in Forbes using Quad Hi-front gutter no slots.

Method

Using the gutter cross sectional area taken from Table 6.2.2 (shown across the bottom of the graph) draw a line upwards until it intersects with the Design rainfall intensity (Table 6.2.1). Draw a line at 90° to determine the catchment area for each downpipe.

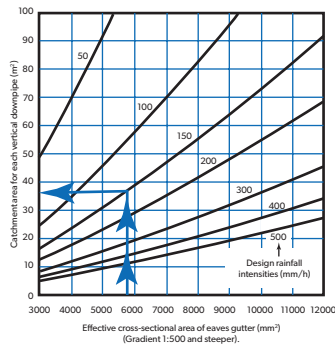

DATA

Design rainfall intensity = 151 (assumed for Forbes)
Gutter area = 5809 (Table 6.2.2)

SOLUTION

Catchment area for each downpipe = 37m²

FIGURE 6.2.3:

Gutter capacity.

Gutter capacity is simply the cross-sectional area of water that the gutter can carry. The water level in the gutter is determined by rules in the code AS/NZS 2179.1 & AS/NZS 3500.3 and is 10mm below the overflow level. The overflow level is either the back of the gutter or the slot level.

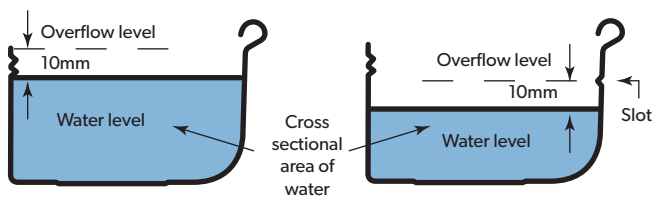

TABLE 6.2.2:

LYSAGHT® gutter areas and downpipes.

	Slotted	Effective cross section	Minimum standard downpipe sizes to suit gutters (gradient ≥ 1:500)	
			Round (diameter)	Rectangular or square
	yes/no	mm ²	mm	mm
Quad Gutter Hi-Front 115 (QGHF)	yes	5225	90	100x50
	no	5809	90	100x50
SHEERLINE® gutter	yes	7600	100	100x75
	no	8370	Note 6	100x75
TRIMLINE® gutter	yes	6244	90	100x50
	no	7800	100	100x75
Half Round (HR) Gutters	See Note 2, 3 & 4			
Half Round Flat Back (HRFB) Gutters	See Note 2, 3 & 4			
Other Quad Gutters	See Note 2, 3 & 4			
Other Rectangular Gutters	See Note 2, 3 & 4			

Notes:

1. Values calculated in accordance with AS/NZS 3500.3 & AS 2179.1.
2. For other gutters refer to the local LYSAGHT® Rainwater Solutions brochure for your area.
3. Downpipe sizes are based on being fitted to the sole of the gutter.
4. Downpipe sizes may vary locally refer to the local LYSAGHT® Rainwater Solutions brochure for your area.
5. For shallower gutter slopes refer to AS/NZS 3500.3 for guidance.
6. Non-standard downpipe and nozzle/pop is required.

Gutter, downpipe and accessory availability and details may vary locally. Reference should be made to the local LYSAGHT® Rainwater Solutions brochure for your area.

PART B: INSTALLATION

7.0 GENERAL CARE, SAFETY AND HANDLING

The following Section should be considered a guide only. For comprehensive information, building professionals should consult the appropriate legislation, regulations, codes of practice and technical literature such as SA HB 39 and LYSAGHT® technical bulletins.

7.1 SAFETY

It is commonsense to work safely, protecting yourself and workmates from accidents on the site. Safety includes the practices you use; as well as personal protection of eyes and skin from sunburn, and hearing from noise. Some sunscreens contain titanium oxides. These have been shown to break down some paint compounds and these should be avoided.

Occupational health and safety laws enforce safe working conditions in most locations. Laws in every state require you to have fall protection which includes safety mesh, personal harnesses and perimeter guardrails. We recommend that you are fully aware of all local codes of safe practice and you adhere strictly to all laws that apply to your site.

7.2 CARE AND STORAGE BEFORE INSTALLATION

Rain or condensation is easily drawn between the surfaces of stacked sheets by capillary action, or they can be driven in by wind. This trapped moisture cannot evaporate easily, so it can cause deterioration of the coating which may lead to reduced life-expectancy or poor appearance.

If materials are not required for immediate use, stack them neatly and clear of the ground and minimise the duration of exposure if left for extended periods. If left in the open, protect them with waterproof covers.

If stacked or bundled product becomes wet, separate it without delay, wipe it with a clean cloth and stack it to dry thoroughly.

7.3 HANDLING CLADDING ON SITE

On large building projects you can reduce handling time by lifting bundles with a crane direct from the delivery truck onto the roof frame. Use a spreader bar for long sheets. For small to medium size projects, without mechanical handling facilities, you can unload sheets by hand and pass them up to the roof one at a time.

Handling Safety - our product may be sharp and heavy.

It is recommended that heavy-duty cut-resistant gloves and appropriate manual handling techniques or a lifting plan be used when handling material.

Handle materials carefully to avoid damage: don't drag materials over rough surfaces or each other; carry tools, don't drag them; protect from swarf.

7.4 WALKING ON ROOFS

It is important that you walk on roofing carefully, to avoid damage to either the roofing or yourself.

If there will be heavy foot traffic or where an area is to be treated as non-trafficable on a roof, provide a temporary walkway or working platform with consideration of hand rails to minimise damage.

Always take particular care when walking on wet or newly laid sheets — particularly on steeply pitched roofs.

Generally, keep your weight evenly distributed over the soles of both feet to avoid concentrating your weight on either heels or toes. Always wear smooth soft-soled shoes; avoid ribbed soles that pick up and hold small stones, swarf and other objects.

Great care should be taken when moving near roof overhang (and overlapping ends of sheets such as expansion joints). The overhang should be treated as a non-trafficable area (Refer to Section 2.3). When walking near an overhang, walk over or as close as practical to the roofing supports (usually over fastener locations). It is not recommended to walk on the overhang due to the potential for large deflections, which can result in a loss of balance and increased potential fall risk. This is of particular importance with overhangs at building edges.

When you walk parallel to the ribs between supports:

- for ribbed roofing walk on at least two ribs or corrugations (CUSTOM ORB®, CUSTOM BLUE ORB®, CUSTOM ORB ACCENT® 21, CUSTOM ORB ACCENT® 35 and SPANDEK®);
- for pan-type roofing walk in the pans (KLIP-LOK® 406, KLIP-LOK 700 HI-STRENGTH®, KLIP-LOK CLASSIC® 700 and TRIMDEK®).

Be careful when moving between supports. Do not walk in the pan immediately adjacent to flashings or translucent sheeting. Walk at least one pan away.

When you walk across the ribs between supports, walk over or close to the roofing supports. (Usually over fastener locations).

7.5 MARKING OUT, CUTTING AND DRILLING MARKING OUT

A pencil of any colour may be used except black or so-called lead pencils. Don't use black pencils to mark roofing or walling because the graphite content can create an electric cell when wet and thus cause deterioration of the finish. You can also use a string line with chalk dust, or a fine, felt-tipped marker.

CUTTING

Where possible, you should minimise site-work by using sheets cut to length in the factory.

For cutting thin metal on site, we recommend that you use a power saw with a metal-cutting blade because it produces fewer damaging hot metal particles and leaves less resultant burr than does a carborundum disc.

Alternative cutting tools (electric shears and nibblers) are also suitable however extra care with the straightness of the cut may be required.

Cut materials over the ground and not over other materials where hot particles can fall and cause damage to finishes—especially COLORBOND® steel pre-painted finishes. It is best to have the exterior colour finish of a COLORBOND® steel pre-painted sheet facing down, however you must then protect the paint finish from scratching by your work supports.

If you have to cut materials near sheets already installed, mask them or direct the stream of hot particles away. Reciprocating nibblers are also widely used in the roofing trade, and they produce an excellent cut.

The resulting small, sharp scraps can rust and damage finishes; and they can cause personal injury. Take special care to collect these scraps.

MAKING HOLES

Holes are often made by drilling or cutting by hole saw or jig saw. Mask the area around the hole to protect paint from damage by swarf.

7.6 CLEAN UP

Swarf (metal scraps and/or abrasive particles resulting from cutting and drilling) left on the surfaces of materials will cause rust stains which can lead to reduced life of the material.

- Sweep or hose all metallic swarf and other debris from roof areas and gutters at the end of each day and at the completion of the installation. Failure to do so can lead to blockages of water flow or surface staining (such as when the metal particles rust).
- If swarf has become stuck on a finish, it can be removed. Take great care not to remove the paint or the metal coatings.
- For critical applications inspect the job two weeks after completion, when rain or condensation will have caused any remaining swarf to rust, and thus highlight affected areas.

7.7 WARN OTHER CONTRACTORS

Many stains arising from swarf do so, not from the work of roofing-installers, but from other contractors working on the job. Similarly, problems can arise from contact with incompatible materials, like copper piping or chemically treated timber. Acid cleaning of bricks can also be a problem. Remember to warn them to walk on pans, not on the ribs. Architects and builders need to be aware of all this, and warn contractors accordingly.

7.8 STRIPPABLE COATINGS

To provide temporary protection during production, handling and transport, some COLORBOND® steel products are coated with a plastic. This coating peels off easily when new, but it has a relatively short life, especially in sunlight. If you don't remove this coating at the time of installation, you may find it very hard to remove later on.

Please dispose of the plastic in an environmentally responsible manner.

7.9 RECOMMENDED SEALANTS

Neutral-cure silicone sealants have been successfully used with the range of steel finishes on our roofing and walling; and on flashings, cappings, and gutters made from the same materials as the cladding.

Neutral-cure silicone sealants:

- have good adhesion to the clean surface of all our roofing and walling;
- are water resistant and non-corrosive;
- are resistant to extremes of heat and cold while retaining good flexibility;
- excellent gap fillers;
- provide high resistance to ultra-violet rays (sunlight); and
- have a long service life.
- they are NOT adhesives.

It is important that only neutral-cure silicone be used with sheet steel. Other silicone sealants, often have a vinegar or ammonia smell, and give off aggressive by-products during curing which are detrimental to sheet steel.

If in doubt, look for a message on the sealant package like: Suitable for use with galvanised and ZINCALUME® steel products.

CLEANING SURFACES

For effective bonding, all surfaces must be clean, dry and free from contaminants such as old sealant or oil.

Mineral turpentine is suitable for cleaning the surfaces but care must be taken to completely remove all residual solvent with a clean dry cloth. White spirits is an alternative.

Sealant must be applied on the same day as the surface is cleaned.

JOINT STRENGTH

Joints sealed with sealant should be mechanically fixed for strength. Spacing of the fixing will depend upon the type of joint to be sealed. Fasteners in joints of simple seams (flat sheet steel joints) should generally be no further apart than 50mm. Fasteners in joints with profiled roofing (e.g. side-lap joints) can be spaced further apart. The spacing of the fasteners shall be based on good and accepted industry practices to ensure suitable bonding of the sealant to the mating surfaces.

The sealant does not require significant adhesive strength in itself, but it must bond positively to all the surfaces it is to seal. To ensure complete sealant cure, the width of sealant in a lap should not exceed 25mm when compressed (Figure 7.9.1).

APPLYING SEALANT

Always apply the bead of sealant in a continuous line along the centreline of the fastener holes. This ensures that, when compressed, the sealant positively seals the fastener.

Be careful not to entrap air when applying sealant. Especially, don't place a ring of sealant around fastener holes because entrapped air compresses during tightening of fasteners, and may blow a channel through the sealant, which could prevent the fastener from being sealed.

FASTENERS

Use solid or sealed fasteners (e.g. screws and blind pop rivets), otherwise you have to apply sealant to the hollow centre of open pop rivets.

To preserve the life of your cladding, it is very important that fastener materials are compatible with the cladding (Section 2.9).

PROCEDURE

The preferred procedure for lap fabrication is:

1. Assemble, clamp and drill;
2. Separate components and remove drilling debris;
3. Clean joint surfaces as recommended above;
4. Apply bead(s) of sealant;
5. Relocate components and fix;
6. Externally seal each fastener if hollow blind rivets are used.

To prevent premature curing (which causes poor bonding), finish the joint as soon as practical after applying the beads of sealant. The manufacturer's specified sealant open times should be followed.

SEALANT CLEAN UP

With practice you will be able to judge the size of beads thus avoiding squeeze-out and the subsequent need to clean up.

Uncured sealant can be removed with a clean, dry rag and any excess then removed with a cloth lightly dampened with mineral turpentine or white spirits. Excess cured sealant is best removed with a plastic spatula to avoid damage to the surface finish of the metal.

Avoid any unnecessary smearing of sealant on surfaces intended for painting as silicone can affect adhesion of paint. Smearred sealant may be treated by lightly abrading the area with a non-metallic scouring medium.

Figure 7.9.1

Typical joints with sealant.

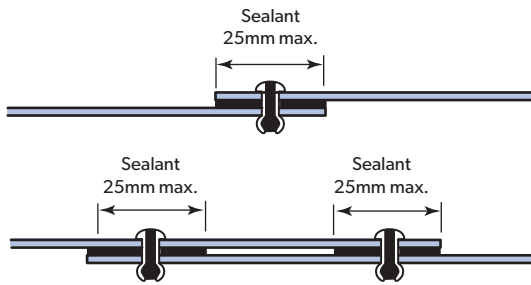
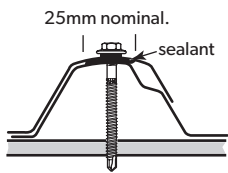

Figure 7.9.1.1

Typical crest with sealant.



7.10 MAINTENANCE

Factors that most affect the long life of a roof (or wall) are original design, the environment of the installation, and the maintenance of the installation. Maintenance is probably the biggest factor.

Maintenance includes:

- Regular inspection for problems before they become major corrosion sites;
- Regular washing down, especially near coastal or industrial influences;
- Removal of leaves and other debris from gutters, downpipes, leaf-guards, slots, holes and other overflow devices;
- Keep walls free of soil, concrete and debris near the ground;
- Don't overspray pesticide.

MAINTENANCE OF COLORBOND® PRE-PAINTED STEEL

The paint system on COLORBOND® steel sheet is very durable. Simple maintenance of the finish enhances its life and maintains attractiveness for longer periods.

Where the paint finish is naturally washed by rainwater (roofs, for example) there is usually no additional maintenance needed. However areas to be washed include soffits, wall cladding under eaves, garage doors, and the underside of eave gutters.

Washing should be done at least every six months and more frequently in coastal areas where sea spray is prevalent, and in areas where high levels of industrial fallout occur. Avoid accumulation of salty deposits or industrial dirt.

Establish a regular routine for washing COLORBOND® pre-painted steel products. Often garage doors can be washed with clean water at the same time as your car is being washed. Guttering and eaves can be hosed down when windows are being cleaned. Walls can be hosed down (if water restrictions permit) while watering the garden.

Where regular maintenance doesn't remove all the dirt, wash the surface with a mild solution of pure soap or non-abrasive non-ionic kitchen detergent in warm water. Use a sponge, soft cloth or soft bristle nylon brush; be gentle to prevent shiny spots. Thoroughly rinse off the detergent with clean water.

Never use abrasive or solvent cleaners (like turps, petrol, kerosene and paint thinners) on COLORBOND® steel surfaces. For advice on grease, oil or deposits not removed by soap or detergent contact our Information Service.

8.0 INSTALLING PIERCE-FIXED CLADDING

Pierce-fixing is the method of fixing sheets using fasteners which pass through the sheet. This is different from the alternative method called concealed-fixing (Chapter 9). The method of fixing you use is determined by the cladding profile you are using.

You can place screws through the crests or in the pans/valleys, however, to maximise watertightness, always place roof screws through the crests. For walling, you may fix through either the crest or valley/pan (Figure 8.1).

Always drive the screws perpendicular to the cladding, and in the centre of the corrugation or rib.

The following procedures are described for roofs, but the same general principles apply to walls.

8.1 GENERAL INSTALLATION PROCEDURE

CHECK FLATNESS, SLOPE AND OVERHANG

Before starting work ensure that:

- the supports for your cladding are truly in the same plane;
- the minimum roof slopes conform to Section 2.5 (Low-roof-pitches); and
- the overhangs of sheets from the top and bottom supports don't exceed those in Table 2.12.1 and Table 2.13.1, whilst also overhanging a nominal length into gutters.

Make any necessary adjustments before you start laying sheets, because they will be difficult or impossible to rectify later.

ORIENT SHEETS BEFORE LIFTING

Ensure that the sheets are orientated correctly – thus the outer/weather surface of the sheets is pointed outward/upward/away from the supports.

ROOFING

Consider which end of the building is best to start from.

It is much easier and safer to turn sheets on the ground than up on the roof. Before lifting sheets on to the roof, check that they are the correct way up and the overlapping side is towards the edge of the roof from which installation will start.

Place bundles of sheets over or near firm supports, not at mid span of roof members.

Industry practice is for the sheets to start laying from the end of the building that will be in the lee of the prevailing weather wherever possible. This is more important when the roofing profile is more vulnerable (shallow profile, simple nesting of the side-laps, longer spans, shallow slopes, etc.) and when the vulnerable roof profile is in exposed situations. Deeper/stiffer roofing profiles and roofing profiles that interlock at the side-lap (e.g. KLIP-LOK® type roofing) have considerably less reliance on laying direction.

WALLING

Generally wall sheets can be installed either vertically or horizontally.

Vertical installation is the more common and the principles above for roofing can be applied.

Horizontal installation is carried out with the first sheet at the bottom with the overlap facing down. Following sheets are progressively installed up the wall.

POSITION FIRST SHEET

With particular care, position the first sheet before fixing to ensure that it is correctly located in relation to other parts of the building.

Check that the sheet:

- is aligned with the end-wall (or its barge or fascia), bearing in mind the type of flashing or capping treatment to be used; and
- aligns correctly at its ends in relation to the gutter and ridge (or parapet or transverse wall).
- overhang requirements are not compromised.

Fix the sheet as described later in this chapter.

POSITION OTHER SHEETS

After fixing the first sheet in position, align the following sheets using:

- the long edge of the previous sheet; and
- a measurement from the end of the sheet to the fascia or purlin at the gutter. It is important that you keep the gutter-end of all sheets in a straight line.

Fix the sheet by either:

- fixing each sheet completely, before laying the next; or
- fix the sheet sufficiently to ensure it can't move, complete laying all sheets, then return to place all the intermediate fasteners later.

CHECK ALIGNMENT OCCASIONALLY

Occasionally check that the sheets are still parallel with the first sheet, by taking two measurements across the width of the fixed cladding (Figure 8.1.2).

At about half way through the job, perform a similar check but take the measurements from the finishing line to aim for the final sheet to be parallel with the end of the roof. If the measurements are not close enough, lay subsequent sheets very slightly out of parallel to gradually correct the error by:

- properly align and fix a lap, then
- fix the other edge of the sheet, placing the fasteners slightly closer or further from where they would normally be if there was no error. (Gradually correct the error by placing the fasteners in such a way as to slowly bring the sheets back into correct alignment).

FIGURE 8.1:

Crest and valley fixing (CUSTOM ORB®).



FIGURE 8.1.1:

Sheet lay direction when prevailing weather is a consideration.

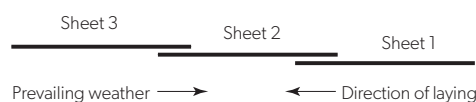
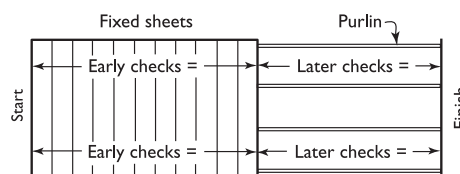

FIGURE 8.1.2:

Check alignment occasionally.



8.2 SIDE-LAPPING & POSITIONING PIERCE-FIXED SHEETS

To prevent moisture being drawn into laps by capillary action, the edges of sheets are slightly modified. CUSTOM ORB®, CUSTOM BLUE ORB® and CUSTOM ORB ACCENT® have the edges of the sheet over-curved, other products like SPANDEK® and TRIMDEK® all have flutes formed into the underlapping rib. It is important that sheets be lapped correctly. The recommended laps for the pierce-fixed claddings are shown in Figure 8.2.1.

After fixing the first sheet, place the next (and subsequent) sheet with its side-lap snugly over the previous sheet (Figure 8.2.1). Secure the sheet firmly in place until each end of the sheet has been fixed.

You can do this easily by:

- align the bottom edge accurately by a measurement from the end of the sheet to the fascia or purlin at the gutter;
- clamp the lap with a pair of vice grips (Figure 8.2.2);
- at the top of the sheet: nestle the side-lap snugly, check alignment, and fix the sheet with a fastener.

8.3 PIERCE-FIXING ON CRESTS

Crest fixing is recommended for roofs made from:

- CUSTOM ORB®
- CUSTOM BLUE ORB®
- CUSTOM ORB ACCENT® 21
- CUSTOM ORB ACCENT® 35
- SPANDEK®
- TRIMDEK®

Crest fixing may also be used for these products when they are used as walling.

FIGURE 8.2.1:

Crest fixing and side-lapping.



CUSTOM ORB® to steel support (typical also of CUSTOM BLUE ORB® and CUSTOM ORB ACCENT® profiles)

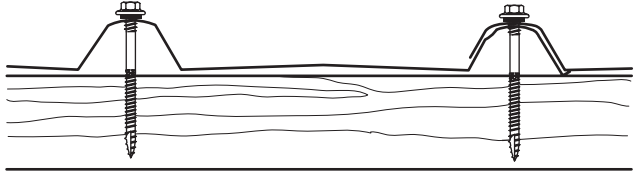

TRIMDEK® to timber support



SPANDEK® to steel support

FIGURE 8.2.2:

Clamp one end of the sheet whilst fixing the other end.

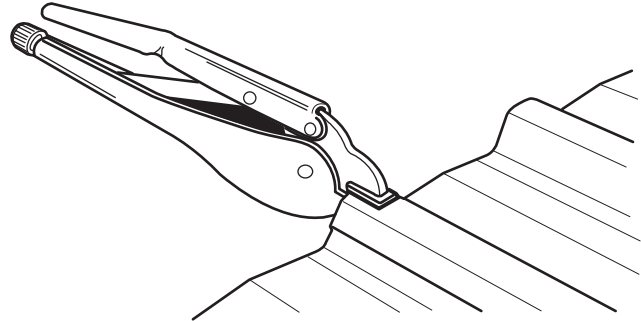

8.4 PIERCE-FIXING ON VALLEYS (FOR WALLING ONLY)

Wall fasteners may be placed on the crests, but they are usually placed in the valley of wall cladding because:

- they are less conspicuous and don't break the aesthetic lines of the steel cladding;
- there is no risk of the profile being deformed, because the fastener is placed through the cladding where it rests flat against its support (Figure 8.4.1); and
- water penetration is not a problem.

However, when valley-fixed, the cladding needs a side-lap fastener in all laps, at each support. You will find it more economical in labour, time and cost of fasteners to use a crest fastener at each side-lap in place of the lap fastener and adjacent valley fastener (Figure 8.4.2).

When the cladding is valley - fixed the fastener must be positioned in the lowest flat portion of the cladding and a nominal clearance from the side of the rib, so that the fastener's head/washer, nor the drive socket, mark the rib profile.

8.5 PIERCE-FIXING ON SIDE-LAPS

Where roofing is installed according to the support spacings shown in Tables 2.12.1 and/or 2.13.1, side-lap fasteners are generally not required between the supports.

You may need to use side-lap fasteners where the cladding is laid a little out of alignment, where the weather resistance of a joint is questionable, at the end of overhangs, where insulation results in the lap opening, or for any number of reasons. Decide on the number of side-lap fasteners by what looks effective in each individual case.

The side-laps of shallow roof profiles on curved roofs (convex and concave) would be considered to have reduced weather resistance, and especially over the crest of the roof due to inadequate drainage from insufficient slope. It is common industry practice to provide side-lap fastening over the curved roof and in particular over the crest region where sealant is used.

Good trade practice is to space the side-lap fasteners at 900mm maximum.

For cyclonic regions where resistance against flying debris is required the maximum recommended spacing of side-lap fasteners is 600mm.

Where valley fasteners are used (walling), you need side-lap fasteners along each lap at each support. Alternatively a crest fastener may be used at each side-lap, in place of the side-lap fastener and adjacent valley fastener (as mentioned above in Section 8.4).

Side-lap fasteners are located in the centre of the crest of the overlapping rib (Figures 8.4.1 and 8.4.2).

FIGURE 8.4.1:

Typical valley fixing (for walls only) and side-lapping.

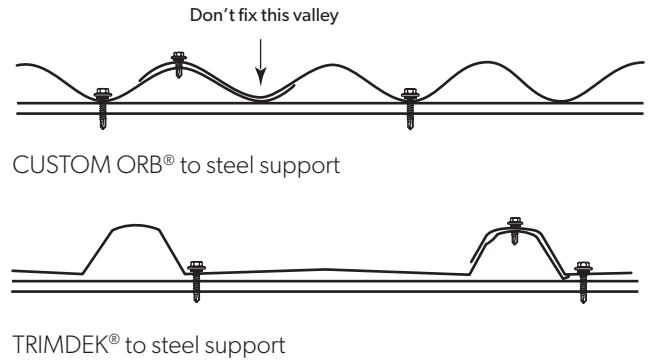

FIGURE 8.4.2:

Alternative valley/pan fixing with crest fixing at side-laps (for walls only).

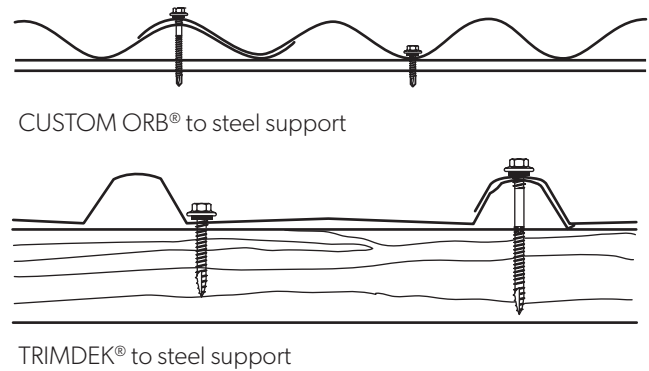
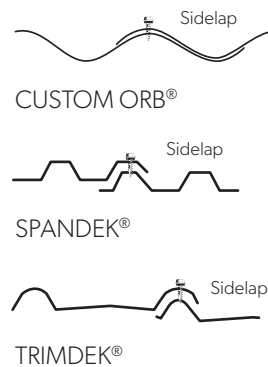

FIGURE 8.4.3:

Side-lap fastening.



9.0 INSTALLING CONCEALED-FIXED CLADDING

Concealed-fixing is the method of fixing sheets using fasteners which do not pass through the sheet. Instead, the cladding is held in place with clips. This is different from the alternative method called pierce-fixing (Chapter 8). The method of fixing you use is determined by the cladding profile you are using.

Concealed-fixing is used for:

- KLIP-LOK 700 HI-STRENGTH®
- KLIP-LOK CLASSIC® 700
- KLIP-LOK® 406

VERY STEEP PITCHES

Pierce-fixing of concealed-fixed claddings is not normally recommended, however there may be some situations with certain concealed-fixed claddings where pierce-fixing may be required. Please contact your nearest Lysaght service centre for guidance when pierce-fixing of certain concealed-fixed claddings.

One situation where pierce-fixing may be required is on very steep pitches, such as in a steep roof or in wall applications.

To prevent concealed-fixed cladding from sliding downward in the fixing clips, on very steep pitches, you should pierce-fix through each sheet under the flashing or capping, along the top of the sheets, but not less than 25mm from the ends of a sheet.

9.1 INSTALLING KLIP-LOK® ROOFS

Use the same general procedure described in Section 8.1 (General installation procedure). However, at the start of installing KLIP-LOK® 406, KLIP-LOK CLASSIC® 700 (KL-CLASSIC) or KLIP-LOK 700 HI-STRENGTH® (KL-700HS) a row of clips is fixed to the supports before the first sheet is located over them and locked in position.

CLIPS

KLIP-LOK 700 HI-STRENGTH® use KL-700HS clips.

KLIP-LOK CLASSIC® 700 use KL-CLASSIC 700 clips.

For KLIP-LOK® 406 use KL-65 clips.

The orientation of the clips is important because they are not symmetrical (Figure 9.1).

The fixing holes are pre-punched. On KL-65 clips you can use the dimples to locate other fasteners where a fastener breaks or a timber support splits.

As there are differences in installation procedures, each type of KLIP-LOK® will be presented separately.

9.2 INSTALLING KLIP-LOK® WALLS

In walling applications, horizontal pressure will need to be applied locally to the sheets to engage the ribs. Use body pressure (torso, hand or foot) or use a rubber mallet if required. Care should be exercised due to the potential instability of the temporary worker access equipment.

To prevent KLIP-LOK® from sliding downward in the fixing clips, you should pierce-fix through each sheet under the flashing or capping, along the top of the sheets.

FIGURE 9.1:

KLIP-LOK® clips.



**KLIP-LOK CLASSIC® clip
(For KLIP-LOK CLASSIC® 700)**

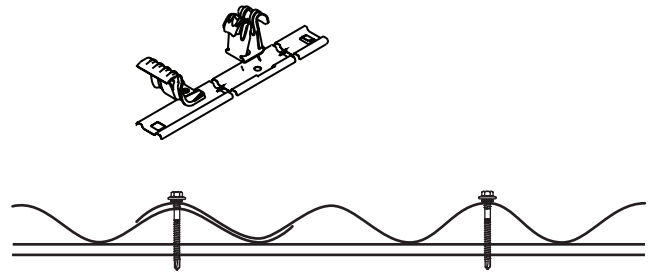

**KL-700 HS fixing clip for
KLIP-LOK 700 HI-STRENGTH®**

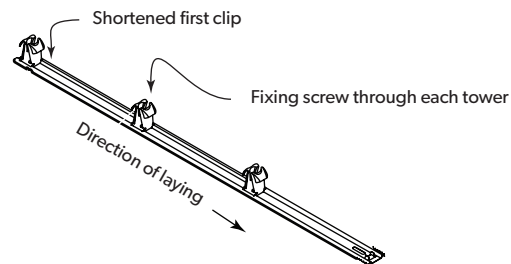

**KL65 fixing clip for
KLIP-LOK® 406**

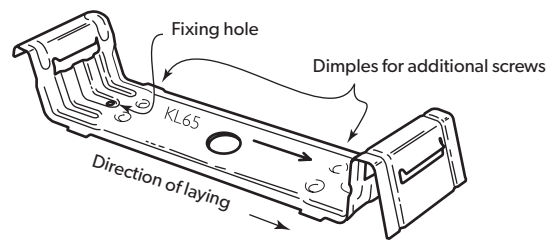

KLIP-LOK 700 HIGH STRENGTH® Installation

KLIP-LOK 700 HI-STRENGTH® PREPARATION

Before starting work ensure that:

- check flatness, slope and overhang;
- orient the sheets before lifting. Note the overlapping rib towards the end of the building where you start;
- check that the overhang requirements of the sheets from the clips, at both gutter and ridge, are not compromised.
- the first and the last supports and clips should be at least 75mm from each end of the sheet to keep maximum holding power.

Make any necessary adjustments before you start laying sheets, because they will be difficult to rectify later.

ORIENT SHEETS BEFORE LIFTING

Ensure that the sheets are orientated correctly – thus the outer/ weather surface of the sheets is pointed outward/upward/away from the supports.

ROOFING

Consider which end of the building is best to start from.

It is much easier and safer to turn sheets on the ground than up on the roof. Before lifting sheets on to the roof, check that they are the correct way up and the overlapping side is towards the edge of the roof from which installation will start.

Place bundles of sheets over or near firm supports, not at mid span of roof members.

Industry practice is for the sheets to start laying from the end of the building that will be in the lee of the prevailing weather wherever possible. This is more important when the roofing profile is more vulnerable (shallow profile, simple nesting of the side-laps, longer spans, shallow slopes, etc.) and when the vulnerable roof profile is in exposed situations. Deeper/stiffer roofing profiles and roofing profiles that interlock at the side-lap (e.g. KLIP-LOK® type roofing) have considerably less reliance on laying direction.

WALLING

Generally wall sheets can be installed either vertically or horizontally.

Vertical installation is the more common and the principles above for roofing can be applied.

Horizontal installation is carried out with the first sheet at the bottom with the overlap facing down. Following sheets are progressively installed up the wall.

Starting method 1. Preferred start (Figure 9.1.2): Cut the 1st clip 25mm from the centre of the second tower or third tower (as shown). The first tower on the cut clip locates in the 1st rib of the first sheet. Two clips must be fixed at the start before any sheets are installed.

Starting method 2. The first tower on the first clip locates in the first rib of the first sheet (Figure 9.1.2). The clip fixes the edge of the first sheet. Installation of the second clip will require the clip to be slightly lifted to allow clip engagement of clip slots/tabs (see step 9 below).

STEPS FOR INSTALLATION

1. Lay and fix wire mesh to the supports and lay the glass wool insulation, all in accordance with the appropriate building requirements.
2. Position the first clips on each support by placing onto the support nearest the roof edge. (Figure 9.1.3).

FIGURE 9.1.1:

Sheet lay direction when prevailing weather is a consideration.

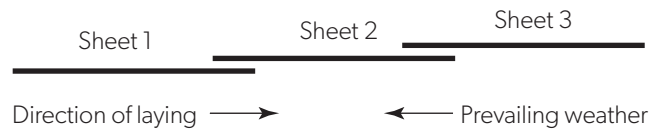
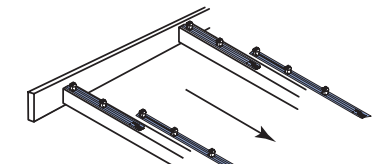
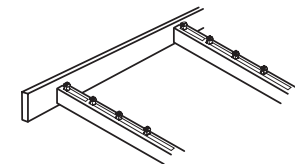
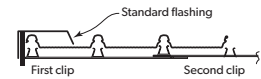
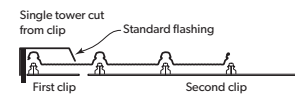
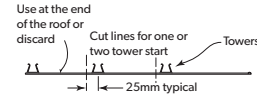

FIGURE 9.1.2:

Alternative methods for first clips.

KLIP-LOK 700HS: Starting method 1 (preferred start)



KLIP-LOK 700HS: Starting method 2 (Alternate start)

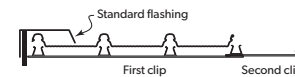

FIGURE 9.1.3:

Fix the first row of clips. Fix the next (and subsequent) clips and sheets.

KLIP-LOK 700 HI-STRENGTH®

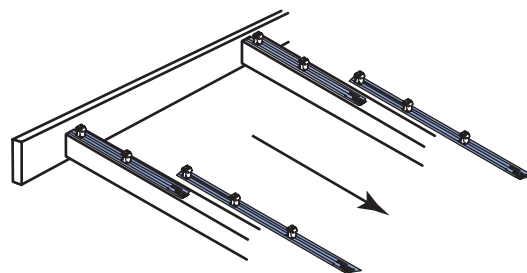
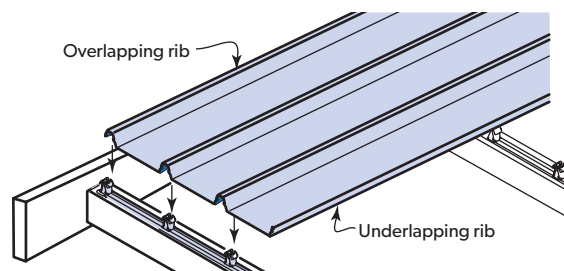

FIGURE 9.1.4:

Placing the first sheet.



3. Fix the first clip on the support so they point in the direction of laying. Ensure the clip is 90 degrees to the edge of the sheet.
4. Align the clips using a string line (or the first sheet as a straight edge) to align the clips as you fix a clip to each support working towards the high end of the roof.
5. Drive hex-head screws through the top of the clip, into the support.
6. Work along the edge of the roof ensuring it aligns correctly at its ends in relation to the gutter and ridge (or parapet or transverse wall).
7. Position the first sheet so that it overhangs the desired amount to the gutter. It is important to ensure this first sheet is placed square to adjacent edges. (Figure 9.1.4).
8. Engage the sheet with clips using vertical foot pressure on all the ribs over each clip.
9. Fix the next row of clips, one to each support with the slots and tabs engaged. Be sure the clip is 90 degrees to the edge of the sheet. It is good practice to bend down the tabs once engaged. This can be done with the bit of a screw gun.
10. As before, place the next sheet over its clips ensuring you also engage the edge of the preceding sheet.
11. Accurately position the sheet so that it overhangs the desired amount into the gutter. It is important that you keep the gutter-end of all sheets in a straight line.
12. Fully engage the two sheets along the overlapping rib. You can do this by walking along the full length of the sheet with one foot in the centre pan of the previous sheet and the other foot applying vertical pressure to the top of the interlocking ribs at regular intervals. It is important that you don't walk in the unsupported pan beside the overlap. (Figure 9.1.5). With long spans, additional care may be required to ensure the overlapping rib adequately engages onto the underlapping leg. Care should be exercised due to the potential instability of the side-lap when it is not adequately engaged (interlocked).
13. Similarly, engage all the clips by applying vertical foot pressure to the top of the other two ribs over each clip.

It is essential that the sheets interlock completely. It is important that your weight is fully on the sheet you are installing.

CHECK ALIGNMENT OCCASIONALLY

Occasionally check that the sheets are still parallel with the first sheet, by taking two measurements across the width of the fixed sheeting.

At about half way through the job, perform a similar check but take the measurements from the finishing line to aim for the final sheet to be parallel with the end of the roof. If the measurements are not close enough, lay subsequent sheets very slightly out of parallel to gradually correct the error (Figure 9.1.6). Therefore, to allow this to happen, flatten the tabs on the base of subsequent clips—the slot in the clip will allow the clips to be fixed out of standard pitch.

FIX THE LAST SHEET

If the final space is less than the full width of a sheet, you can cut a sheet along its length and shorten the clips as appropriate.

FIGURE 9.1.5:

Engaging the lapping ribs.

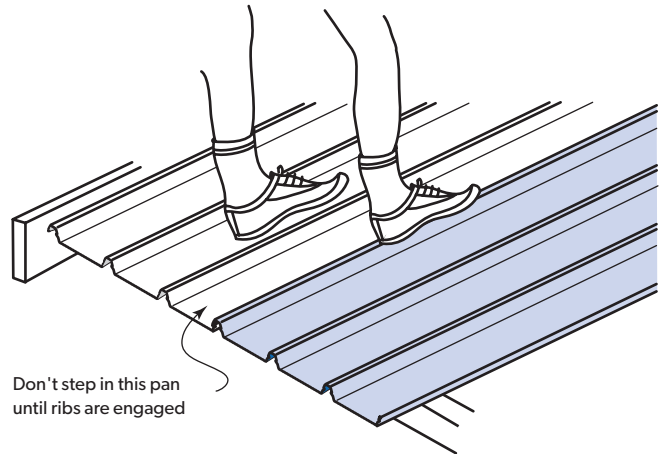
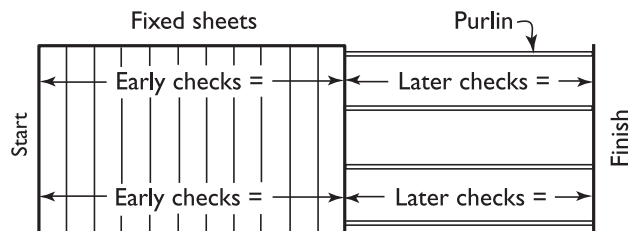

FIGURE 9.1.6:

Check alignment occasionally.



KLIP-LOK CLASSIC® 700 Installation

KLIP-LOK CLASSIC® 700 PREPARATION

Before starting work ensure that:

- The supports for your cladding are truly in the same plane, this is critical if the roof slope is $\leq 5^\circ$.
- The minimum roof slopes conform to our recommendations.
- The overhangs of sheets from the top and bottom supports are not compromised.
- The first and last supports and clips should be at least 75mm from each end of the sheet to keep maximum holding power.

Make any necessary adjustments before you start laying sheets, because they will be difficult to rectify later.

ORIENT SHEETS BEFORE LIFTING

Ensure that the sheets are orientated correctly – thus the outer/weather surface of the sheets is pointed outward/upward/away from the supports.

ROOFING

Consider which end of the building is best to start from.

It is much easier and safer to turn sheets on the ground than up on the roof. Before lifting sheets on to the roof, check that they are the correct way up and the overlapping side is towards the edge of the roof from which installation will start.

Place bundles of sheets over or near firm supports, not at mid span of roof members.

Industry practice is for the sheets to start laying from the end of the building that will be in the lee of the prevailing weather wherever possible. This is more important when the roofing profile is more vulnerable (shallow profile, simple nesting of the side-laps, longer spans, shallow slopes, etc.) and when the vulnerable roof profile is in exposed situations. Deeper/stiffer roofing profiles and roofing profiles that interlock at the side-lap (e.g. KLIP-LOK® type roofing) have considerably less reliance on laying direction.

WALLING

Generally wall sheets can be installed either vertically or horizontally.

Vertical installation is the more common and the principles above for roofing can be applied.

Horizontal installation is carried out with the first sheet at the bottom with the overlap facing down. Following sheets are progressively installed up the wall.

KLIP-LOK CLASSIC® 700 INSTALLATION

1. Lay and fix wire mesh to the supports and glass wool insulation in accordance with the appropriate building requirements.
2. Position the first clips on each support by placing onto the support nearest the roof edge. (Figure 9.1.8).
3. Fix the first clip on the support so they point in the direction of laying. Ensure the clip is 90 degrees to the edge of the sheet.
4. Align the clips using a string line (Figure 9.1.9) or the first sheet as a straight edge to align the clips as you fix a clip to each support working towards the high end of the roof.
5. Drive hex-head screws through the top of the clip, into the support.
6. Work along the edge of the roof, ensuring it aligns correctly at its ends in relation to the gutter and ridge or parapet or transverse wall.

FIGURE 9.1.7:

Sheet lay direction when prevailing weather is a consideration.

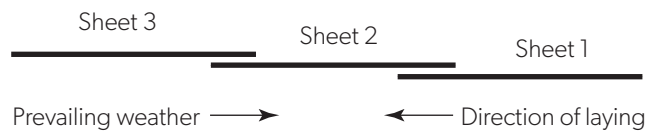

FIGURE 9.1.8:

Sequence of laying.

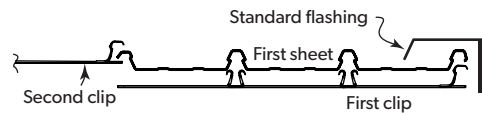

FIGURE 9.1.9:

Use a stringline to ensure first row of clips is aligned. Fix first row of clips.

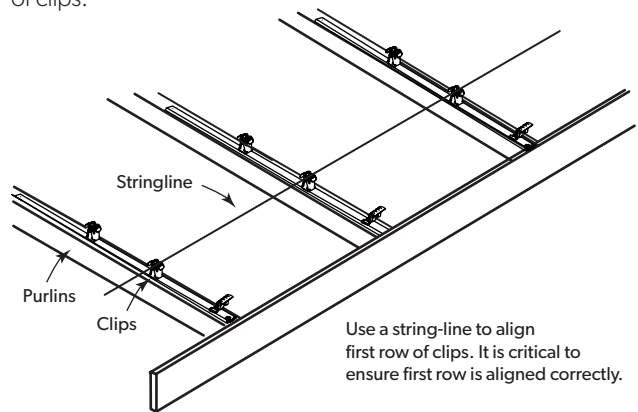

FIGURE 9.1.10A:

Placing the first sheet.

KLIP-LOK CLASSIC®

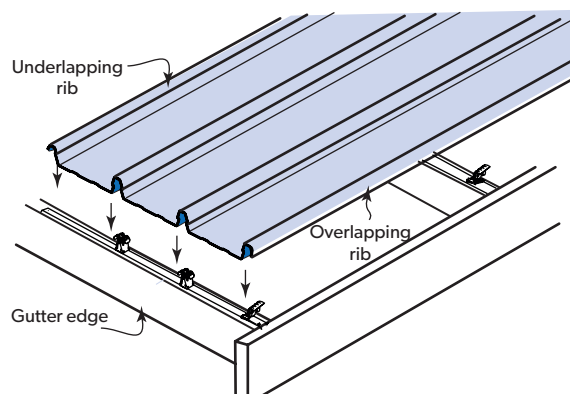

FIGURE 9.1.10B:

Position the 'S' clips over the male lapping rib of the cladding.



7. Position the first sheet so that it overhangs the desired amount to the gutter. It is important to ensure this first sheet is placed square to adjacent edges. (Figure 9.1.10).
 8. Engage the sheet with clips using vertical foot pressure on all the ribs over each clip.
 9. Fix the initial overlapping rib of the first sheet using an 'S' clip. (See Figure 9.1.10b).
 10. Fix each next row of clips one to each support by engaging the front of the clip assembly onto the underlap rib of the preceding sheet engaging the spur of the clip to the leading edge of the previous sheet. (Figure 9.11.1 & 9.1.12) Be sure the clip is at 90° to the edge of the sheet.
 11. As before, place the next sheet over its clips ensuring you also engage the edge of the preceding sheet.
 12. Fully engage the two sheets along the overlapping rib. You can do this by walking along the full length of the sheet with one foot in the centre pan of the previous sheet and the other foot applying vertical pressure to the top of the interlocking ribs at regular intervals. It is recommended that you don't walk in the unsupported pan beside the underlapping rib. (Figure 9.1.13).
- With long spans, additional care may be required to ensure the overlapping rib adequately engages onto the underlapping leg. Care should be exercised due to the potential instability of the side-lap when it is not adequately engaged (interlocked).
13. Similarly, engage all the clips by applying vertical foot pressure to the top of the other two ribs over each clip. It is essential that the sheets interlock completely. It is important that your weight is fully on the sheet you are installing.
 14. Fit an 'S' clip at the last rib of the profile (similar to Step 9 when the sheet was started). Both starting and finishing requires an 'S' clip.

CHECK ALIGNMENT OCCASIONALLY

Occasionally check that the sheets are still parallel with the first sheet, by taking two measurements across the width of the fixed sheeting. At about half way through the job, perform a similar check but take the measurements from the finishing line to aim for the final sheet to be parallel with the end of the roof. If the measurements are not close enough, lay subsequent sheets very slightly out of parallel to gradually correct the error. (Figure 9.1.14)

FIX THE LAST SHEET

If the final space is less than the full width of a sheet, you can cut a sheet along its length and shorten the clips as appropriate. It is desirable to fix the sheet at one end.

FIGURE 9.1.11:

Fix the next (and subsequent) clips and sheets.

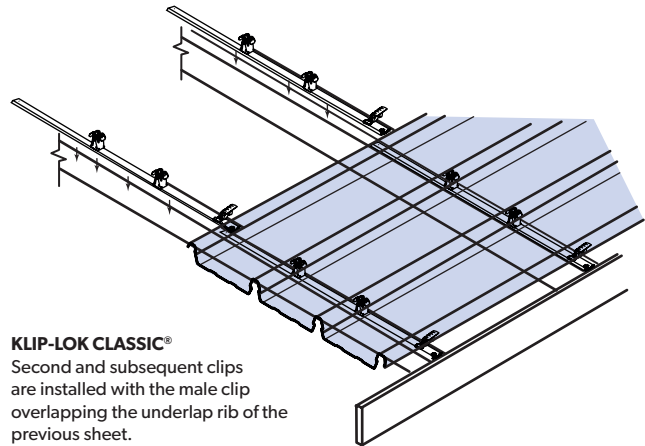

FIGURE 9.1.12:

Engaging the next clip to the first sheet.

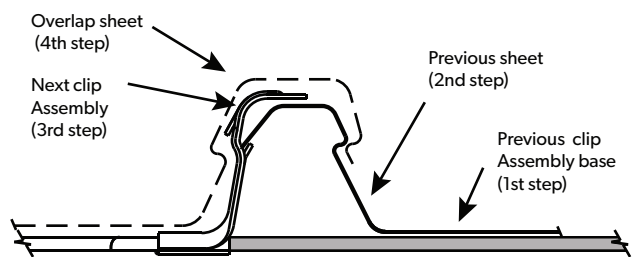

FIGURE 9.1.13:

Engaging the lapping ribs.

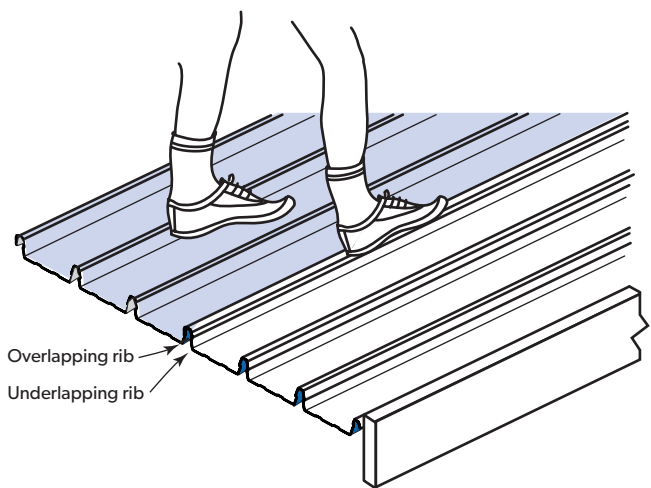
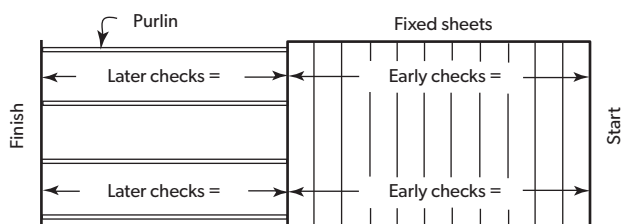

FIGURE 9.1.14:

Check alignment occasionally.



KLIP-LOK® 406 Installation

KLIP-LOK® 406 PREPARATION

Before starting work ensure that:

- Check that the top faces of all purlins or battens are lying in one plane, adjusting as necessary by packing or easing between these members and their supporting structure. Under no circumstances should packing be used directly under the fastening clips to adjust fall or alignment of roof.
- The minimum roof slopes conform to our recommendations; and
- The overhangs of sheets from the top and bottom supports are not compromised.
- The first and last supports and clips should be at least 75mm from each end of the sheet to keep maximum holding power.
- Make spot checks for the alignment of sheets during laying to control fanning or creep (5 sheets = 2030mm coverage). To rectify alignment, sheets may be adjusted 2mm by pulling the clip away or pushing towards the sheet while fastening the clip.
- For very steep roof or vertical wall applications, a positive fastener (screw or bolt) is required in each sheet length to prevent movement down the fastening clips. This is best positioned under or through the flashing or capping at the top end.
- KLIP-LOK® 406 can be fastened over insulation wool blankets up to 50mm thick when the blanket is draped over supports before installation of clips.
- Sheets should project into the gutter line.

Accurate alignment ensures efficient locking of sheets and clips. Conversely, misalignment can interfere with the locking action, particularly on close support centres. Make any necessary adjustments before you start laying sheets, because they will be difficult to rectify later.

STEPS FOR INSTALLATION

STEP 1

When lifting sheet lengths onto the roof frame ready for installation, make sure all sheets have the overlapping ribs facing towards the side where fastening is to commence. (Figure 9.1.15).

The first run of clips must be located and fastened, one to each support, so that they will correctly engage in the overlapping and centre ribs of the first sheet when it is located and locked over them. To do this, fasten clips to the purlins at each end of the sheet, having positioned them so that the first sheet will be in correct relation to other building elements. Align and fasten the remainder of the first run of clips using a string line or the first sheet as a straight edge.

STEP 2

Position the first sheet longitudinally in relation to gutter overhang and locate it over the fastened run of clips, positioning the centre rib first, and engage the centre and overlapping ribs onto all clips by foot pressure. (Figure 9.1.18).

FIGURE 9.1.15:

Sheet lay direction when prevailing weather is a consideration.

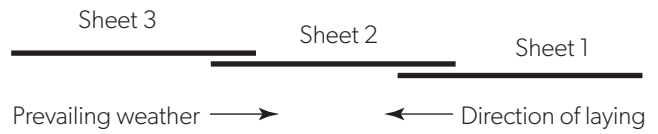

FIGURE 9.1.16:

Starting method for KL-406.

KLIP-LOK® 406 (KL65 clips shown)

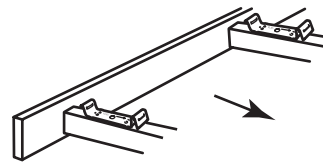

FIGURE 9.1.17:

Orient the sheets correctly before installation on clips.

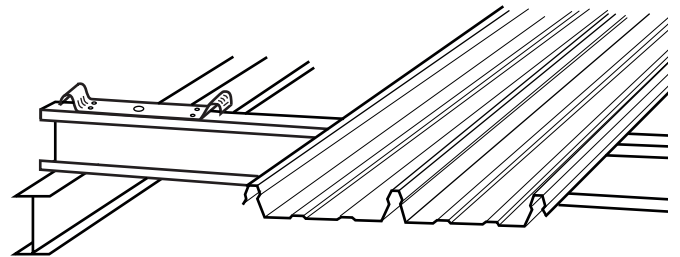

FIGURE 9.1.18:

Position the first sheet of the run of clips.

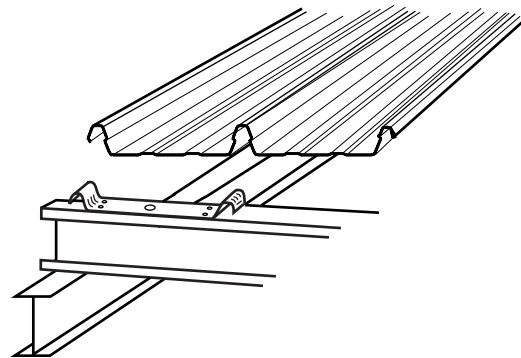
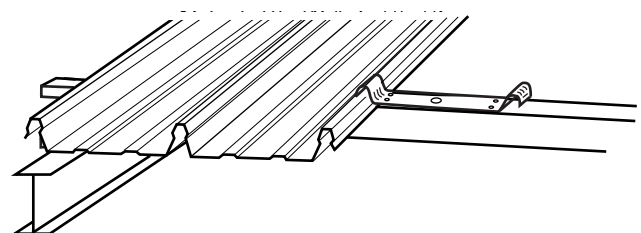

FIGURE 9.1.19:

Position the next row of clips over the underlapping rib of the first sheet and fix clip to supports.



STEP 3

Position and fasten the next run of clips, one to each support, with the short return leg of the clip over the underlapping rib of the installed sheet. (Figure 9.1.19).

If the clip fouls one of the spurs spaced along the outer free edge of the underlapping rib, the spur can be flattened with a blow from a rubber mallet to allow the clip to seat down over the rib.

STEP 4

Place the second sheet over the second run of clips, again positioning the centre rib first. A string line stretched across the bottom alignment of the sheets can be used to check that the ends of the sheets are in line. (Figure 9.1.20).

Fully engage the interlocking ribs and the centre rib over each clip. (Figure 9.1.21).

This can be achieved by walking along the full length of the sheet being installed with one foot in the tray next to the overlapping rib and the other foot applying pressure to the top of the interlocking ribs at regular intervals.

Also apply foot pressure to the top of the centre rib over each clip. For complete interlocking, which is essential, the spurs of KLIP-LOK® 406 along the underlapping rib must be fully engaged in the shoulder of the overlapping rib.

A distinct “click” will be heard as the interlocking ribs fully engage.

When engaging KLIP-LOK® 406 interlocking ribs, stand only on the sheet being installed, that is the overlapping sheet, and not on the preceding sheet.

Install subsequent sheets by following Steps 3 and 4 and make periodic checks that the installed sheets are aligned with the roof perimeter.

STEP 5

If the space left between the last full sheet and the fascia or parapet is more than a half sheet width, a sheet can be cut longitudinally, leaving the centre rib complete. This partial sheet can be fully clipped onto a row of clips as for a full sheet, before installing the capping or flashing. If the space left between the last full sheet and the fascia or parapet is less than a half sheet width, it can be covered by the capping or flashing. In this case, the last sheet should be secured by cutting sheet in halves and fastening the underlapping rib at each purlin with a half sheet. (Figures 9.1.22 & 9.1.23).

Similarly, a half clip may also be used if required. In this case, where a partial sheet of less than two ribs is used, it is necessary to turn up the lip along the edge of the cut sheet.

This can then be covered by the capping or flashing.

FIGURE 9.1.20:

Lay the next row of sheeting over the next row of clips.

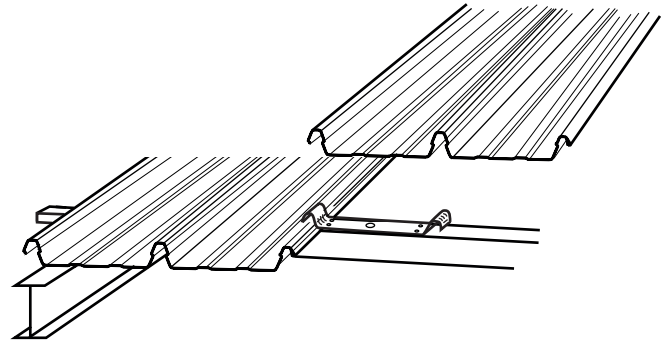

FIGURE 9.1.21:

Engaging the lapping ribs.

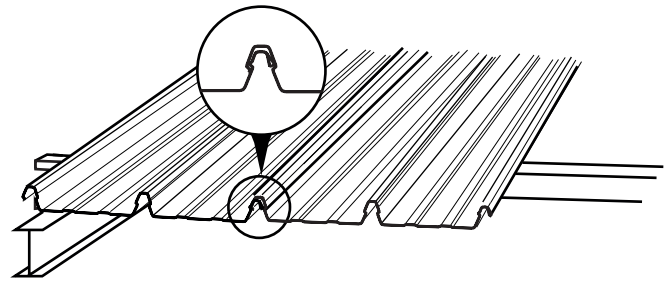

FIGURE 9.1.22:

KLIP-LOK® 406

Placing last sheet where half a sheet will fit.

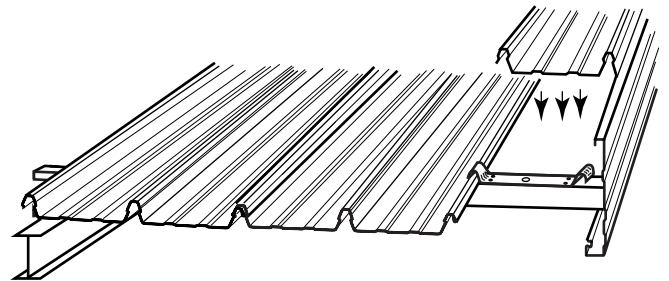
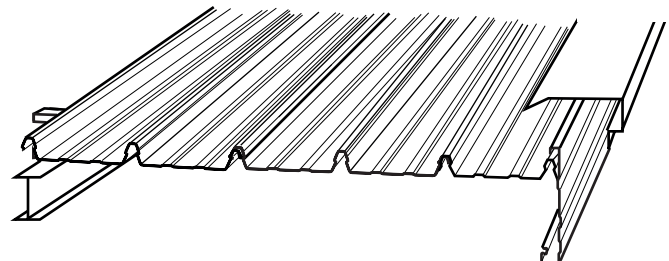

Figure 9.1.23:

KLIP-LOK® 406

Placing last sheet where half a sheet won't fit.



10.0 ENDS OF SHEETS

This chapter describes how you can treat the ends of sheets to maximise weather resistance, environmental protection and vermin resistance.

10.1 TURN-UPS

At the high end of roofing, wind can drive water uphill, under the flashing or capping, into a building. To minimise this problem, you turn up the valleys (or pans) at the high end of roofing. (The process is called turning-up (or stop-ending).

All roofing on slopes below 1 in 2 (25°) should be turned-up.

Turn-up tools are available for all our roofing profiles except CUSTOM ORB®, CUSTOM ORB ACCENT® 21 and CUSTOM ORB ACCENT® 35 (Figure 10.1.1).

During the turn-up operation, care should be exercised to prevent tearing or puncturing the steel sheets.

You can turn-up sheets before or after they are fixed on the roof. If you do the latter, you must have sufficient clearance for the turn-up tool at the top end of the sheets (about 50mm).

TURNING-UP CUSTOM ORB®, CUSTOM ORB ACCENT® 21 & CUSTOM ORB ACCENT® 35

With pliers, multi-grips or a shifting spanner closed down to approximately 2mm, grip the valley corrugations 20mm in from the end of the sheet and turn up as far as possible (Figure 10.1.2). Be careful not to tear the sheet.

TURNING-UP TRIMDEK® AND SPANDEK®

Slide the turn-up tool onto the end of the sheet as far as it will go. Holding the tool against the end of the sheet, pull the handle to turn up the tray about 80° (Figure 10.1.3).

TURNING-UP KLIP-LOK®

You get the best results by first cutting off the corner of the down-pointing leg of each female rib. Do this before you place the sheets on the roof.

- With the hinged turn-up tool open: position the tool on the sheet with the locating pins hard against the end of the sheet.
- Hold the handles together to clamp the tool onto the tray, and pull them to turn-up the tray 90° (Figure 10.1.4).

FLUSH TURNING-UP KLIP-LOK® 406

In normal turning-up of KLIP-LOK®, the tops of the ribs protrude past the turned up tray. Consequently the turn-ups cannot be positioned hard against a fascia or wall, or the ends of the sheets on either side of the ridge cannot be butted together. This is usually of no consequence because the turn-up is completely covered by a flashing or capping. However, if you want the ribs not to protrude past the turn-up, you can make a flush turn-up. You need an extra 40mm in sheet length for flush turn-ups.

1. Cut the top of each rib before turning-up the pans (Figure 10.1.5). Turn-up the pans as described before.
2. Position the backing tool (if available) in the tray and hold it hard against the turn-up with a foot.
3. With a rubber mallet, fold the protruding 'ears' flush against the backing tool.

FIGURE 10.1.1:

Turn-up and turn-down tools.

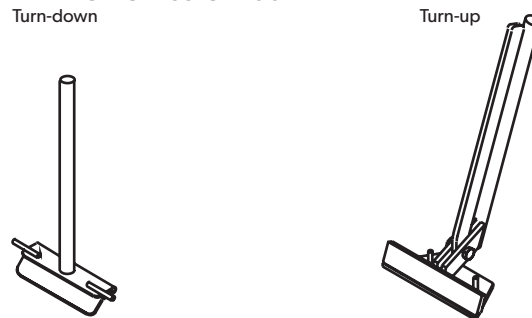
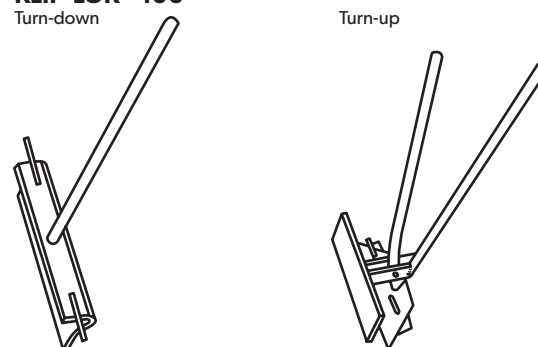
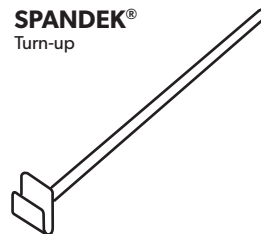
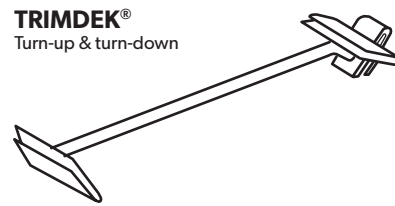

FIGURE 10.1.2:

Turning-up CUSTOM ORB®, CUSTOM BLUE ORB® and CUSTOM ORB ACCENT®.

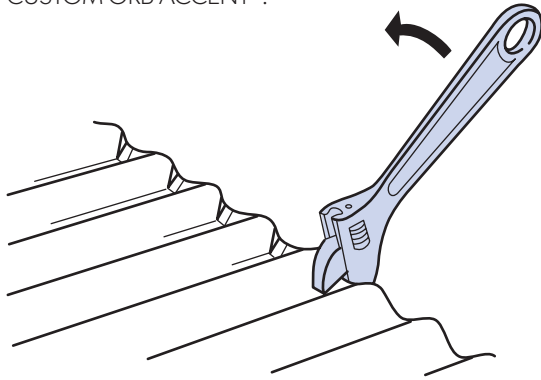

FIGURE 10.1.3:

Turning-up (TRIMDEK® shown).

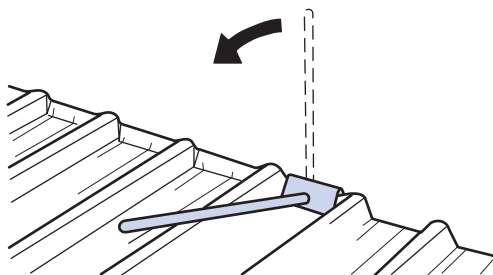

FIGURE 10.1.4:

KLIP-LOK® tool ready for turn-up.

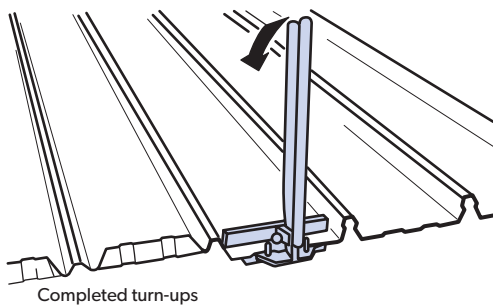
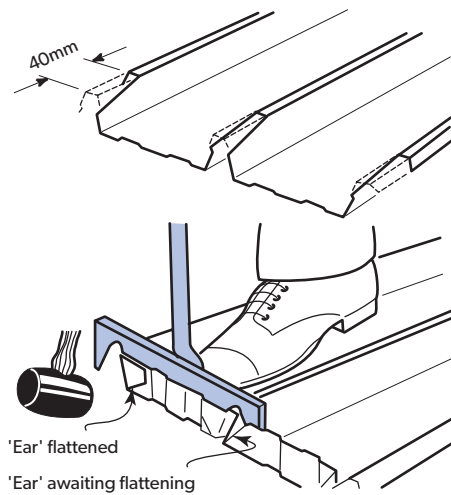

FIGURE 10.1.5:

Using the backing tool for flush turn-up on KLIP-LOK® (G300 steel shown).



10.2 TURNING-DOWN

10.2.1 TURNING-DOWN TRAYS

When wide tray sheeting is used on roof slopes below 1 in 5 (10°) the end of the trays at the low end of the sheeting should be turned down slightly with a turn-down tool. At the low end of roofing, wind or capillary action can cause water to run back up the underside of the flat trays of the sheeting. The process is called turning-down (or lipping).

Turn-down tools are available for TRIMDEK®, KLIP-LOK® 406 and KLIP-LOK 700 HI-STRENGTH®.

During the turn-down operation, care should be exercised to prevent tearing or puncturing the steel sheets.

Turning-down is usually done after the sheeting is fixed on the roof, provided there is no obstruction to the operation of the turn-down tool.

- Push the turn-down tool over the end of the tray, as far as it will go.
- Hold the tool hard against the end of the tray and push the handle to form a turn-down about 20°.

10.2.2 TURNING-DOWN RIBS

When sheeting is placed on low sloped roofs consideration should be given to blocking off rib cavities as described in Section 10.3. One method available, and sometimes practiced, on some roof sheeting is by turning down the rib crests at the ends of the sheeting on the low end of the sheeting.

The turn-down of ribs can be achieved on some roofing profiles. During the turn-down operation, care should be exercised to prevent tearing or puncturing the steel sheets. Turning-down is usually done after the sheeting is fixed on the roof, provided there is no obstruction to the operation of the turn-down tool or process.

TRIMDEK® has a tool available. Push the turn-down tool over the end of the rib, as far as it will go, then hold the tool hard against the end of the rib and pull the handle until the rib is turned to a near vertical position, resulting in a nominal 90° degrees lip. Be careful not to tear the sheet. For safety reasons and aesthetics the corner of the female overlap lip should be cut off prior to the installation of the sheet. Stitching the side-lap ribs at the end of the sheet may be required to ensure a neat nesting at the lap.

10.3 BLOCKING OFF RIB CAVITIES

Dust, insects, birds, rodents, bushfire embers and wind-driven rain and pollutants can enter a building through the cavities under ribs. To minimise these problems the cavities can be blocked off. The blocking off could be achieved by the use of infill strips, turn-down of ribs where possible or, where available, by rib stop-ends. Blocking off rib cavities may also assist with such problems in situations where roof slopes are installed at below the minimum recommended.

In severe environments blocking off of the ribs is recommended, especially with clip - fixed claddings, to protect the cladding fasteners and clips.

FITTING KLIP-LOK® 406 RIB END-STOPS

In some regions, the rib stop-ends for KLIP-LOK® 406 may be available.

When fitting KLIP-LOK® 406 rib end-stops during the sheet installation then fix the rib end-stops to the side of the eaves support after the KLIP-LOK® clip has been secured in position. Align the rib end-stops with the upstands of the fixing clips (Figure 10.3.1).

FIGURE 10.2.1A:

Turning-down the gutter end (TRIMDEK® shown).

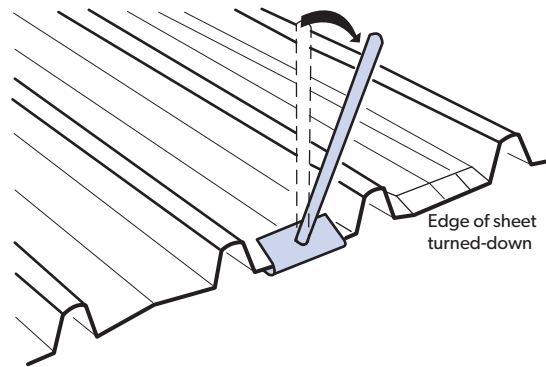

FIGURE 10.2.1B:

Turning-down the gutter end.

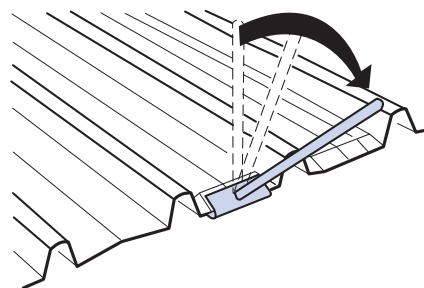
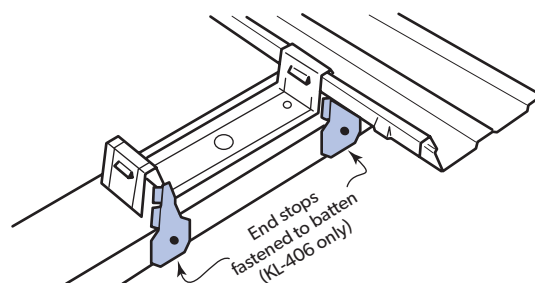

FIGURE 10.3.1:

Fitting rib end-stops during installation of sheets.



When fitting KLIP-LOK® 406 rib end-stops after the sheet installation then bend the flat of the end-stops 90°. Push an end-stop into the space under each rib until the flat is wedged firmly between the underside of the cladding and support (Figure 10.3.2).

INFILL STRIPS

Closed-cell, foam-plastic infill strips are available to match the top or bottom profile of our roof claddings.

At the lower end of cladding, the strip is sandwiched under the roof cladding and on the lower side of the cladding to protect the fasteners/clips. Similarly, at the upper end, the strip is sandwiched between topside of the roofing and the underside of the flashing or capping (Figure 10.3.3).

Don't use infill strips that can absorb water because retained moisture can lead to deterioration of the sheet coating. Avoid using infill strips made from, or treated with, flammable materials, particularly in areas prone to bushfire (Section 11.8).

Where roof pitches are below 1 in 5 (10°), you should incorporate infill strips to maximise resistance to water entry.

10.4 END-LAPPING

Because our roofing and walling is manufactured by continuous processes, sheet lengths can be supplied up to the limits of transport regulations which are frequently long enough to cover roofs without end-lapping the sheets.

If you contemplate using sheets that are shorter than the full span, and end-lap them, you need to consider:

- the roof slope, because it affects the amount of end-lap (see Table 10.4.1);
- the method of fixing of the cladding to its supports, because it affects the maximum length of sheet (see Section 10.5 - Expansion joints and Table 10.5.2).
- treat purlin spacings at laps and expansion joints as End Spans.

FIXING METHODS FOR END-LAPS

PIERCE-FIXED SHEETS:

Position the lap centrally over the support; and the fastening secures both the lap and the cladding. For roofing (Figure 10.4.1a) position the crest fasteners as detailed in Table 3.8.1, and for walling (Figure 10.4.1b) position the valley/pan fasteners as detailed in Table 3.8.1. For cladding with two fastener patterns, use the pattern with the greater number of fasteners (e.g. for CUSTOM ORB® use 5 fasteners/sheet/support pattern).

CONCEALED-FIXED SHEETS:

The lap should be positioned just clear, and on the high side of the support (Figure 10.4.1c). This will allow normal concealed fastening at the support and thus allow thermal movement to occur at the clip. The lap is secured with pierce fasteners through the pan/valley. For alternative lapping of concealed-fixed cladding, by fixing through the valley/pan directly into the support (similarly to that detailed for walling above) please contact your nearest service centre for advice.

FIGURE 10.3.2:

Fitting rib end-stops to KLIP-LOK® 406 after installation of sheets.

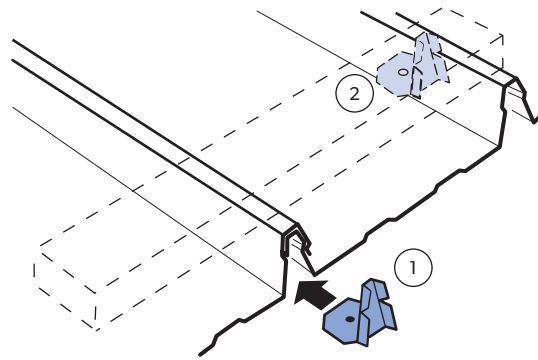

FIGURE 10.3.3:

Profiled closed-cell infill at eaves.

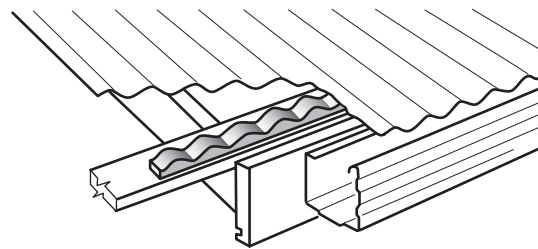

FIGURE 10.4.1:

Fixing at end-laps.

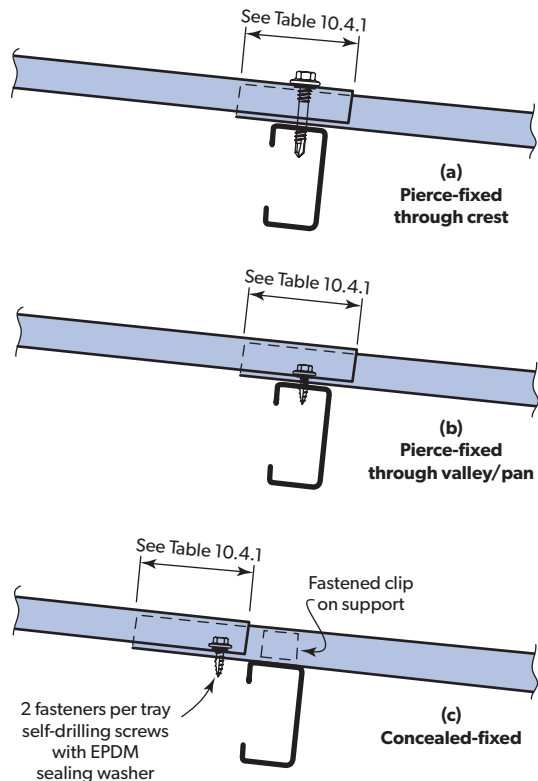

TABLE 10.4.1:

End-laps.

	End-lap minimum (mm)	End-lap maximum (mm)
Roof Slope		
Less than 1 in 4 (15°)	200	300
Greater than 1 in 4 (15°)	150	250
Walls	100	200

To make the end-lapping of KLIP-LOK® 406 easier: remove, for the length of the lap, the down-turn of the underlapping ribs of the upper and lower sheets in each sheet run (Figure 10.4.2). The cut-back ribs are covered by the sheets of the next sheet run and provide an added stitch screw through the side of the ribs.

KLIP-LOK 700 HI-STRENGTH® & KLIP-LOK CLASSIC® are not recommended to be end-lapped. Instead, an expansion joint must be used. (Refer to Section 10.5 below.) Ideally long length sheets from a mobile rollformer should be used where possible (KL-700HS) as this eliminates the need for end-lapping.

ORDER OF LAYING

Lay each run of sheets in turn from lower to upper before moving on to the next run.

SPACING OF SUPPORTS AT END-LAPS

For the maximum spacing between purlins, either side of an end-lap in a roof, use the spacing given for end spans (terminology and spacing in Table 2.13.1).

END-LAPS IN PITCHES LESS THAN 15 DEGREES

End-laps in roofs of less than 1 in 4 (15°) slope should be sealed with a sealant.

Use two runs of sealant (Figure 10.4.4):

- one run of sealant at the low end of the lap (to prevent moisture being drawn in by capillary action);
- the other run at the high end (to prevent condensation from running down the underside of the top sheet and entering the lap).

When the sheets are lapped together and fixed, the compressed sealant should just appear at the end of the lap.

1. With the top sheet upside down, extrude a 3mm bead of sealant across the underside of this sheet about 25mm from the end.
2. Position the bottom sheet, then extrude a 3mm bead of sealant across the top of the sheet to encapsulate the cut end of the underlapping sheet.
3. Turn the top sheet over and fit it in place.

The side-lap between sheets of roofing has a cavity to prevent capillary action between adjacent sheet runs (Section 8.2).

It is important that excess sealant extruded from an end-lap does not enter this cavity because, if it does, moisture that may have entered the side-lap will not be able to drain unimpeded down the roof slope.

FIGURE 10.4.2:

Remove down-turn of male rib when end-lapping. KLIP-LOK® 406

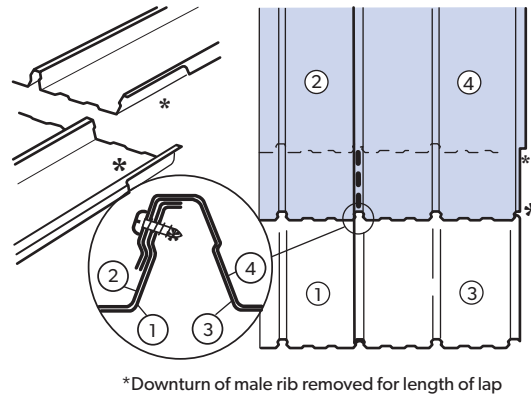

FIGURE 10.4.3:

Laying sequence for end-lapped sheets.

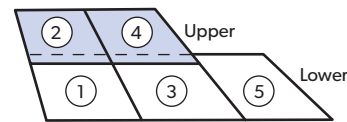
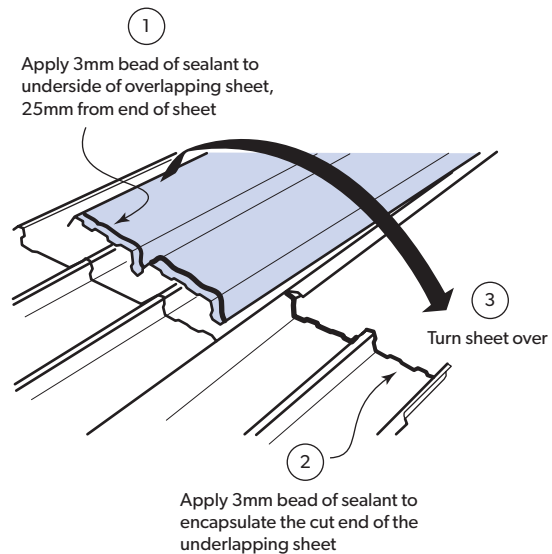

FIGURE 10.4.4:

Sealing end-laps on very low pitched roofs.



10.5 EXPANSION

BACKGROUND ON THERMAL EXPANSION

All metals expand and contract with changes in temperature. Although steel is by far the least affected of all the metals commonly used for roof and wall cladding, the changes in length experienced in very long runs of roofing are significant.

On a clear hot summer day, with no wind, the steel temperature in roof cladding can reach approximately 50°C in COLORBOND® steel in colour SURFMIST®, 60°C in plain ZINCALUME® steel and more than 80°C in COLORBOND® in colour NIGHT SKY®.

Examples of the thermal changes in lengths of steel cladding that would result from various temperature changes in the steel are shown in Table 10.5.1.

The actual expansion or contraction between the end of a sheet and the last support would only be a fraction of the figures shown because the movement in the length of fixed cladding would normally take place from the centre towards each end of the sheet. The movement at each end is thus only half the total expansion or contraction.

Transverse thermal expansion poses no problems in ribbed cladding because each rib absorbs some transverse movement.

EXPANSION JOINTS

1. PIERCE-FIXED CLADDING

Thermal expansion effects are mitigated by slight bending of fastener shanks, thermal movement of the building structure, and slight flexing of the purlins. However, for very long runs of roofing, you should include a traditional expansion joint to overcome linear thermal expansion.

Table 10.5.2 shows the maximum distance between the top and bottom rows (last rows at sheet ends) of fasteners on a pierce-fixed sheet. If the total length of two sheets pierce-fixed through the lap, or a single sheet exceeds this distance, then a traditional expansion joint is needed. There should be no more than one pierce-fixed end-lap between expansion joints.

Table 10.5.2 assumes that there is some flexibility in the roof design (see above). Where flexibility is reduced, such as hard fixing to stiff eaves supports, then added expansion details may need to be incorporated.

A traditional expansion joint involves overlapping the ends of the upper sheets over the ends of the lower sheets—but with a clearance between them (about 15mm). A typical overlap is 250mm (this overlap is not the same as the overhang in Table 2.12.1 which does not apply to expansion joints). The clearance is usually created by having all the purlins for the roofing on the high side of the joint, higher than the roofing on the low side of the joint. An extra purlin is needed at the joint. A baffle flashing provides weatherproofing. See Figure 10.5.1.

Where there is a risk of high winds, or the ribs result in a large opening, you may need protection, such as extra flashing or the inclusion of closed-cell foam infill strips.

When the roofing is at its rainwater capacity limits (e.g. at long shallow roof runs, exposed applications where high winds are likely), it would be prudent for take added precautions to minimise the potential of wind-driven rainwater to enter the expansion joint. For slope consideration refer to Section 2.5 and call your nearest service centre for advice on added guidance with respect to added baffle flashing, insert strips and rib turn-down.

For TRIMDEK® a hybrid joint is available to allow thermal expansion. The hybrid expansion joint called Trim-Klip (see Figure 10.5.1a). The joint involves overlapping the ends of the upper sheet over the end of the lower sheet using a bracket (Trim-Klip bracket) nesting between and located over the purlin line, resulting in an overall step depth of about 20mm. There is no need for an extra purlin at the joint as with the traditional expansion joint. A weather strip(s), between the upper and lower sheets, provides protection from wind-blown rain.

TABLE 10.5.1:

Thermal expansion and contraction of steel cladding.

Sheet length (mm)	Expansion or contraction (mm)		
	10°C change	50°C change	75°C change
5000	0.6	3	4.5
10000	1.2	6	9
15000	1.8	9	13.5
20000	2.4	12	18
25000	3.0	15	22.5
30000	3.6	18	27

TABLE 10.5.2:

Maximum distance between top & bottom rows of fasteners on a sheet, before expansion joint is needed.

Fixing system	Maximum distance between top and bottom rows of fasteners (m)
Pierce-fixed through crests	24
Walling pierced-fixed in valleys/pans	15

FIGURE 10.5.1:

Traditional expansion joint detail.

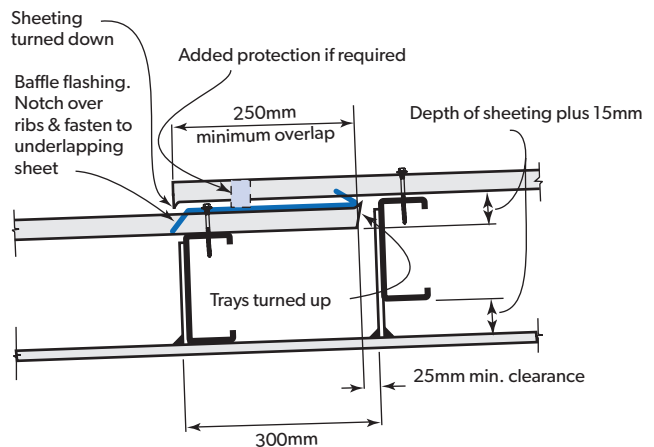
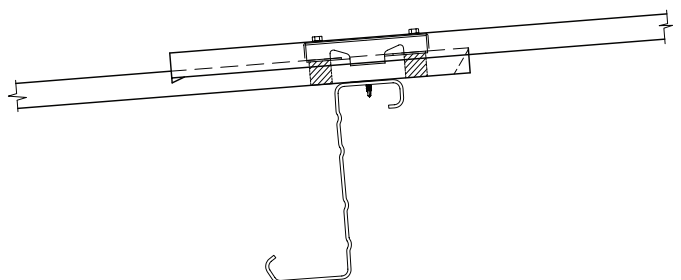

FIGURE 10.5.1A:

TRIM-KLIP® Expansion joint detail.



2. CLIP-FIXED CLADDING

For clip-fixed claddings the thermal expansion effects are mitigated by the differential movement between the cladding and the clips (i.e. slippage). Thus for very long runs expansion joints are generally not required when the cladding is in a single length.

When the run is made up of shorter lengths then an expansion joint may be required when:

- The cladding profile cannot be end-lapped (such as for KL-700HS & KL-700 CLASSIC), or
- More than two sheets are required to be end-lapped to make up for the run (such as for KL406).

For KL-700HS & KL-CLASSIC a hybrid joint is available to allow thermal expansion. The hybrid expansion joint called LOK-KLIP® (see Figure 10.5.2). The joint involves overlapping the ends of the upper sheet over the end of the lower sheet using a bracket (LOK-KLIP® bracket) nesting between and located over the purlin line, resulting in an overall step depth of about 20mm. There is no need for an extra purlin at the joint as with the traditional expansion joint. A weather strip, between the upper and lower sheets, provides protection from wind-blown rain.

10.6 ROOF OVERHANG WITH EDGE STIFFENER

For the stiffened overhangs listed in Table 2.13.1, you need to stiffen the gutter ends of the roofing.

Our SHEERLINE® gutter, fixed through the return lip to the underside of roofing at 200mm centres will provide the required stiffening.

Alternatively, you can use a 50 x 50 x 1.2mm galvanised/ ZINCALUME® steel angle fixed at 200mm centres to the underside of the roofing about 50mm from the end.

10.7 SHEET-ENDS ON LOW SLOPES

For claddings laid on slopes of 5 degrees or less, the underlap lip of the under-sheet may require to be cut back on the corner at the downhill discharge end (gutter end), of the sheet, to block capillary action (Figure 10.7).

This may be required where the return lip of the under-lapping sheet nests snugly with the overlapping sheet without a gap or only a nominal gap, where there is an expected high volume/depth of water discharging, where the sheet ends are exposed to the direct effect of wind, or where there is interference with the down-turning of the pan/valley.

FIGURE 10.5.2:

LOK-KLIP® expansion joint detail.

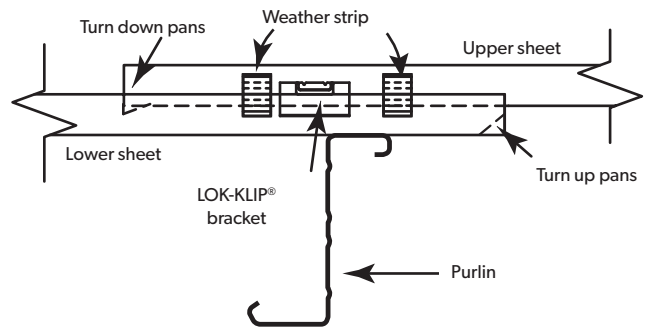
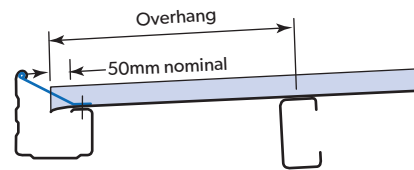
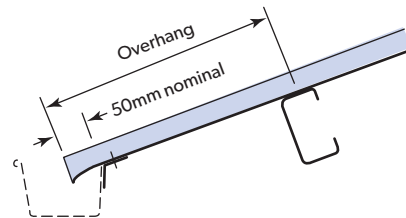

FIGURE 10.6.1:

Methods of stiffening roof overhangs.



Sheerline gutter fixed to underside of roofing (200mm centres)



Galvanised or ZINCALUME® steel angle 50x50x1.2mm fixed to underside of roofing (200mm centres). Gutter may be fixed to angle.

FIGURE 10.7:

Typical cut on low slopes (SPANDEK® profile shown).

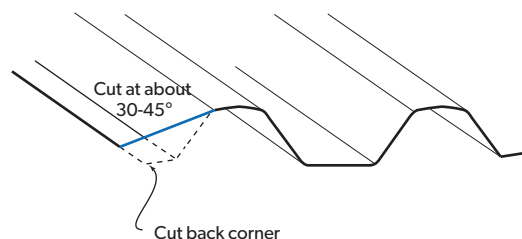

11.0 Flashings

Flashings and cappings are strips of metal formed to weatherproof the edges of roofing and walling.

For the purposes of this chapter, only the term flashing is used. The following sections should be considered as a guide only.

For a comprehensive account of flashing guidelines, refer to SA HB 39 and acceptable trade practices. Our publication 'Architectural Detailing Guide' which is available at www.lysaght.com provides more guidelines.

Similar methods of flashing are used for different cladding-profiles. You can adapt the principles to suit your application.

In all cases it is important to have ample cover provided by the flashing and proper turn-up of the cladding underneath.

The fixing of flashings should follow the minimum industry accepted practices (some practices shown in these guides). Added fixing consideration should be considered in situations of higher exposure to wind. The quantity and position of fasteners should consider the following;

- Located to minimise the length of unsecured overhangs.
- Located along both long edges of the flashings
- Where an edge cannot be secured by fasteners then some other method of securing must be considered (e.g. clips, overlapping stiffening strips, other suitable restraint).

Be careful when moving between supports. Do not walk in the pan immediately adjacent to flashings or translucent sheeting. Walk at least one pan away.

Lysaght has a range of standard flashings. We can also supply custom flashings to your requirements – ask your local service centre for details.

As stated in the Introduction, this book refers to non-cyclonic conditions. For cyclonic conditions we recommend you get professional advice to ensure particular needs are adequately met and local authority approvals are obtained.

11.1 MATERIALS

It is very important that flashings be made from materials that are compatible with the cladding (Section 2.10).

Lead flashing is not recommended, however it will usually be retained when re-roofing, because it is usually cemented into the structure. In these cases:

- the top surface of the lead flashing must be painted with a good quality exterior paint system (to limit contamination with lead compounds in water running off the flashing); and
- there must be a barrier between the lead flashing and the cladding: either a plastic strip (such as polythene dampcourse), or paint.

Flashings should conform to AS/NZS 2179.1, and be compatible with the cladding (Section 2.10).

Materials for flashings are available in ZINCALUME® steel or COLORBOND® steel.

11.2 LONGITUDINAL FLASHINGS

Longitudinal flashings run parallel to the pans or valleys, and are made to suit the cladding profile (Figure 11.2.1). They should have an edge turned-down to dip into the pan or valley.

FLASHING COVER

The minimum recommended cover of longitudinal flashings over cladding should be as follows: (as taken from SA HB 39).

Pierce-fixed roof sheet	150mm min.
Concealed fixed roof sheet	Into full pan (2/3 pan covered)

FIGURE 11.2.1:

Typical longitudinal flashings.

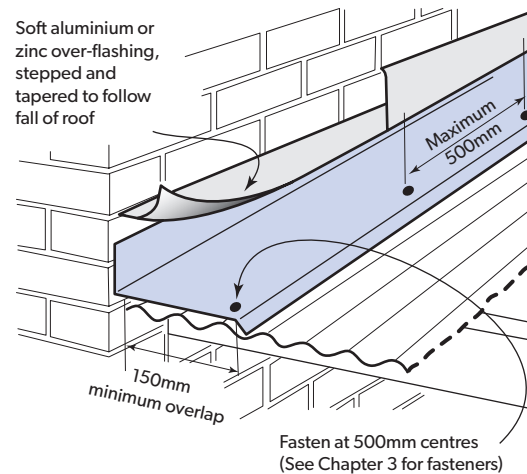
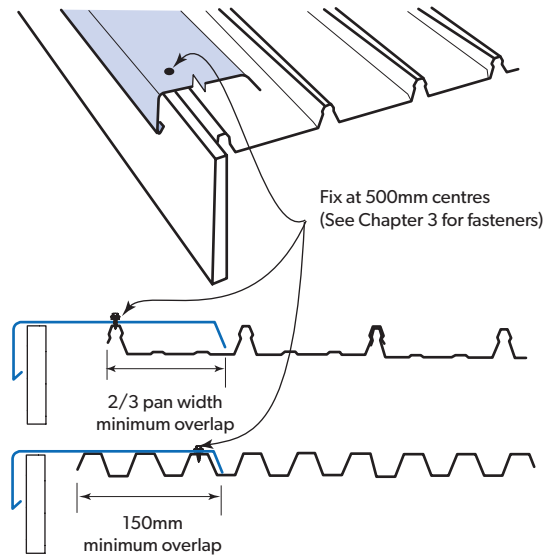

11.3 TRANSVERSE FLASHINGS

Transverse flashings run across the pans or valleys (Figure 11.3.1). They usually have a stiffening lip, along the lower edge, which is turned-down to dip into the pan or valley. To maximise weatherproofing, the bent lip is commonly fashioned (such as notching or scribing) to fit the profile.

Fashioning is preferred for low-slope roofs and/or where exposed to high wind.

The turn-down for transverse flashings for wide panned cladding is always notched or scribed to fit over the ribs.

For CUSTOM ORB®, CUSTOM BLUE ORB® or CUSTOM ORB ACCENT® 21 profiles, the turn down for transverse flashing can also be fashioned by lightly pressing into the valleys, however this depends upon the type of method used for the flashing. For steep-sloped roofs where the roll-top ridge style is used the fashioning is not done.

FLASHING COVER

Lysaght produces a range of standard flashings (hip, barge, apron). To increase weathertightness, Lysaght recommends you maximise the overlap between flashings and claddings.

FIXING OF FLASHINGS

Longitudinal flashings shall be fastened at maximum 500mm centres. Transverse flashings shall be fastened in accordance with SA HB 39, as detailed below.

Profile (min.)	Recommended Fixing Space
CUSTOM ORB®/CUSTOM BLUE ORB®	Every 4th rib
CUSTOM ORB ACCENT® 21	Every 4th rib
CUSTOM ORB ACCENT® 35	Every 2nd rib
KLIP-LOK® 406	Every rib
KLIP-LOK 700 HI-STRENGTH®	Every rib
KLIP-LOK CLASSIC® 700	Every rib
SPANDEK®	Every 3rd rib
TRIMDEK®	Every rib

The above fastener spacing relates to the stitching of flashings to sheeting. It does not constitute the minimum number of fasteners required to fix the sheeting to purlins.

NOTCHING TOOLS

Hand-operated notching tools cut one notch at a time. Each tool matches only one cladding profile. There are two types of tool; their use depends on whether or not the edge of the flashing has first been bent down (Figure 11.3.2).

TABLE 11.3.1:

Notching tools.

Type of tool	Edge turned down before notching	Available for
Horizontal notching tools	No	Availability subject to inquiry
Vertical notching tools (also called speed notchers)	Yes	CUSTOM ORB ACCENT® 35 KLIP-LOK® 406 KLIP-LOK 700 HI-STRENGTH® KLIP-LOK CLASSIC® 700 SPANDEK® TRIMDEK® Others subject to inquiry

FIGURE 11.3.1:

Typical transverse flashings.

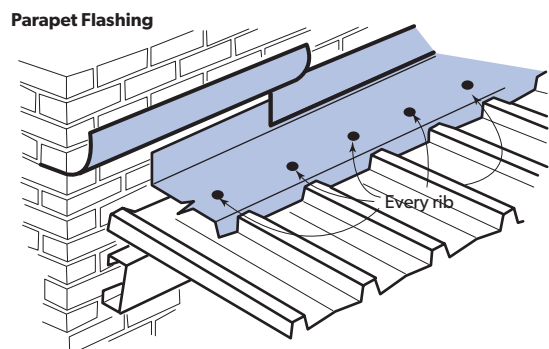
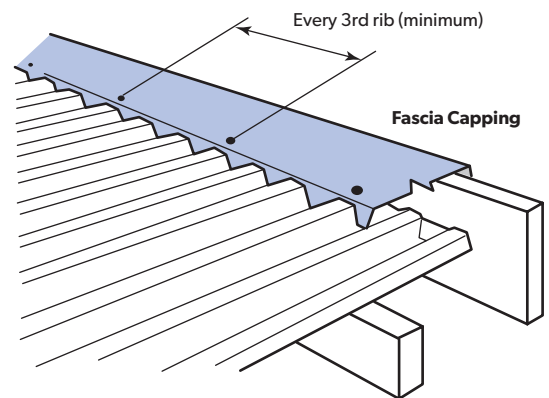
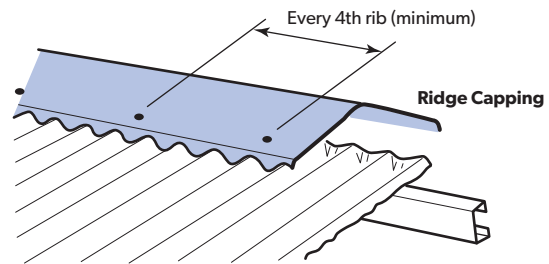

USING NOTCHING TOOLS

After the cladding is fixed and the turn-ups finished, proceed as follows.

- Place a flashing with the notch-edge resting on the ribs.
- Locate your notching tool over a rib with the notching head against the flashing. Vertical tool: The body locates along the rib. Horizontal tool: the lugs on the underside locates on top of the rib.
- Raise the handle to open the tool and:
vertical tool: lift the flashing into the mouth of the tool;
horizontal tool: slide the mouth of the tool over the edge of the flashing as far as it will go.
- Push down on the handle to perform the notching.
- Repeat for all ribs, checking in each case that the flashing is correctly positioned.
- If you are using a horizontal tool, bend down the tongues between the notches over a suitable straight edge (such as a piece of timber).

NOTCHING WITH TINSNIPS

If notching tools are not available, flashings can be notched to the rib profile with tinsnips (Figure 11.3.3). The procedure is sometimes known as scribing. After the cladding is fixed and the turn-ups finished, proceed as follows.

- Place the flashing with the turned-down edge resting on the ribs.
- Mark out the notching using a template positioned over each rib.
- Cut the notches with tinsnips.

This procedure is also used for hip cappings.

FASTENERS FOR TRANSVERSE FLASHINGS

You must properly fix both flashings and the ends of all sheets.

Where the cladding is pierce-fixed through crests, and the position of the purlin allows it, the fasteners used to fix the sheets, may also fix the flashings.

On all other installations, pierce-fix your flashing to the ribs or crests of the sheets.

FIGURE 11.3.2:

Using notching tools.

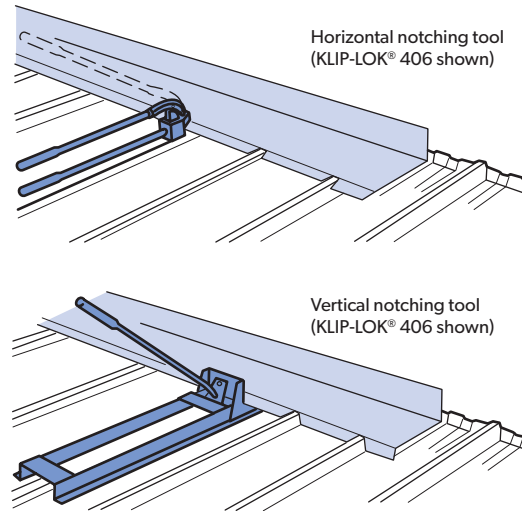
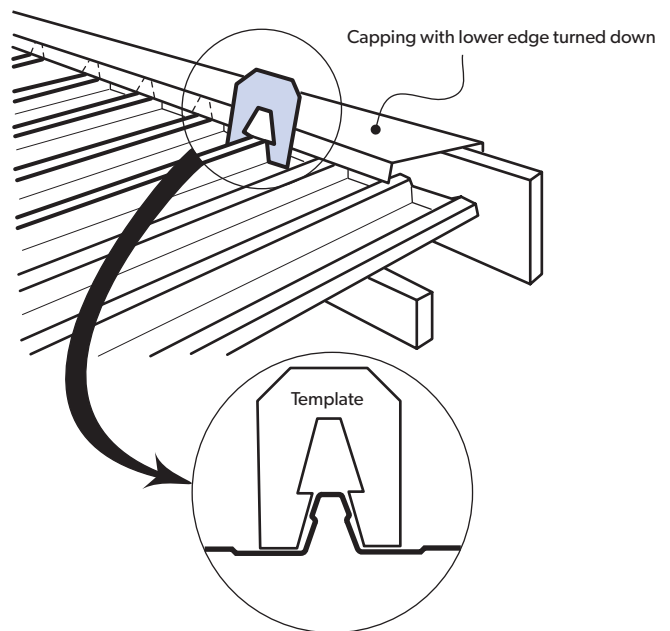

FIGURE 11.3.3:

Using a template to mark out for notching with tinsnips.



11.4 FLASHING AT CHANGE OF PITCH

JOINING FLASHINGS

The overlaps of transverse flashings should be sealed with a recommended sealant and fastened. Before finally positioning and fixing the lap, turn over the top piece and apply a 3mm bead of sealant across the flashing, about 12mm from the end.

11.5 FLASHING LARGE ROOF PENETRATIONS

Penetrations through ribbed cladding block the valleys (or pans), and thus affect the free flow of rainwater down a roof. All flashings have to weatherproof the cladding – but on the uphill side of large penetrations, they also have to channel rainwater sideways into valleys that run unobstructed to the eaves.

Four methods are described here. In all methods the ends of cut ribs may be closed off with caps on the outside of the rib, or with plugs inside the ribs. Plugs must be used on side-laps to allow the anti-capillary cavity to drain.

Note: For masonry construction, Building Code Australia (BCA) requires the use of Damp Proof Course (DPC) to ensure weatherproofing. For acceptable methods see BCA section on weatherproofing masonry.

SUPPORT FRAMING

Wherever one or more of the sheet ribs are cut, you must provide framing to support the cut ends of the roof cladding each side of the penetration.

EXISTING FLASHING

If you have to re-use lead flashings that are built into the structure, special protection is needed (Section 11.1).

METHOD 1: HEAD GUTTER AND APRON FLASHINGS

This is often the simplest method, and commonly used for existing protrusions (Figure 11.5.1). See also Figure 2.4.1.

METHOD 2: FLAT TRAY AND SLEEVE

To avoid fitting and sealing end caps to all the sheet ribs on the low side of the penetration, an apron flashing can be fitted to the sleeve and sealed to the tray each side.

METHOD 3: TRAY GUTTER FOR STEEPER ROOFS

If the roof pitch is more than, say 1 in 12 (5°), you cut the roof cladding sufficiently high above the penetration to allow a tray gutter to raise rainwater over the top of the sheet ribs and divert it around the penetration (Figure 11.5.3).

METHOD 4: PENETRATION CLOSE TO RIDGE CAPPING

If a roof penetration is close to a ridge capping (or flashing above the penetration), you can fit a simple flat tray, on top of the roofing, so that it extends from under the capping down to a sleeve around the penetration.

FIGURE 11.4.1:

Typical flashing at changes of pitch.

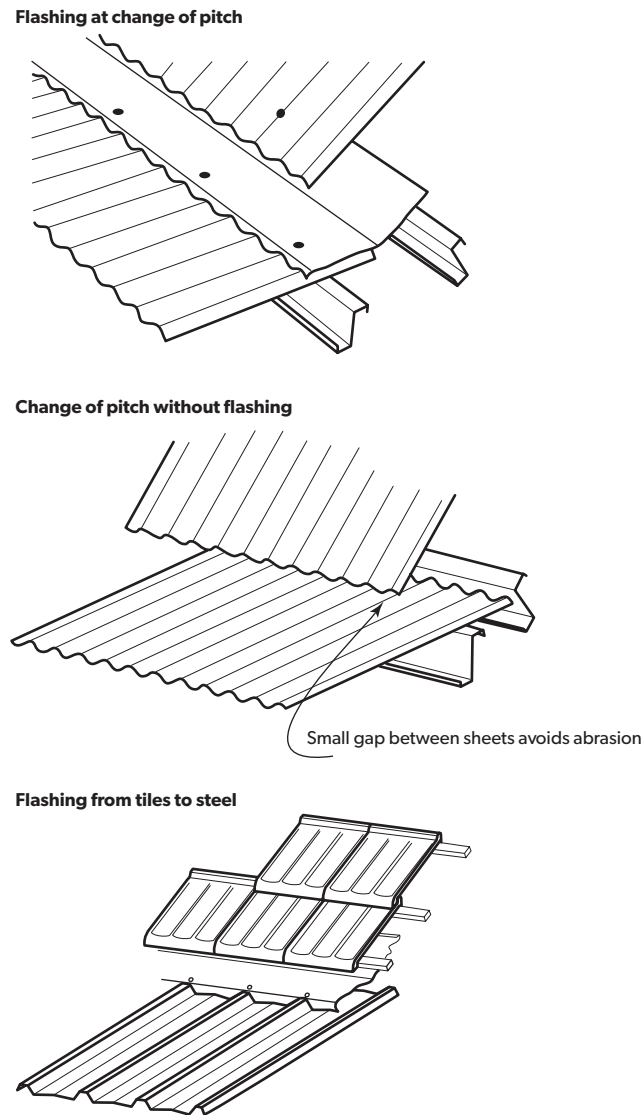

FIGURE 11.5.1:

Flashing method 1: Head gutter.

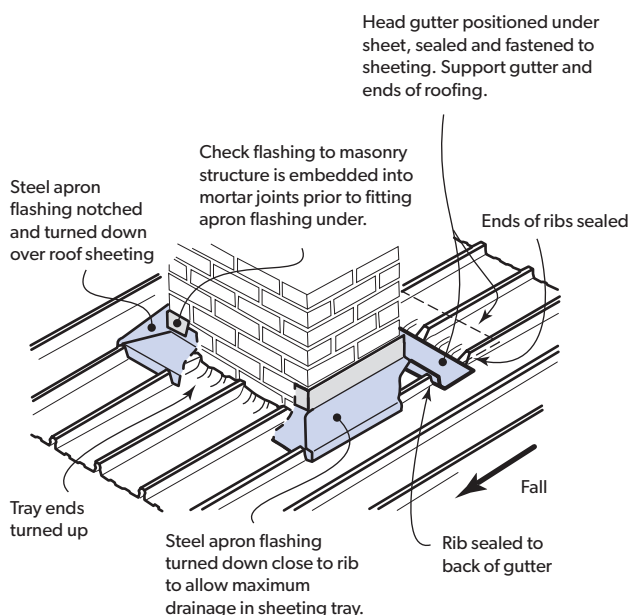
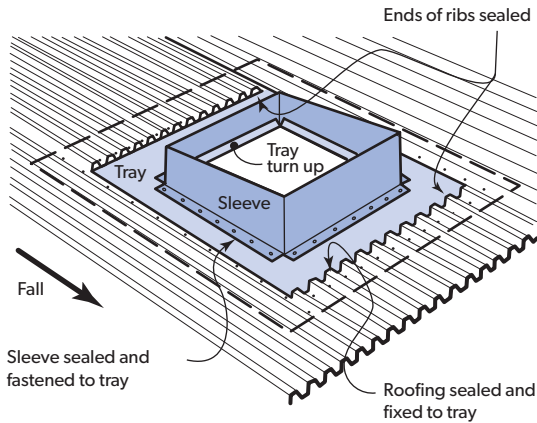

FIGURE 11.5.2:

Flashing method 2: Flat tray and sleeve.

Ribs closed and sealed

Sleeve has clearance around protrusion.
Flash top of sleeve with over-flashing from protrusion.



Sleeve with apron

Tray sealed and fixed to roofing
Apron flashing turned down between ribs

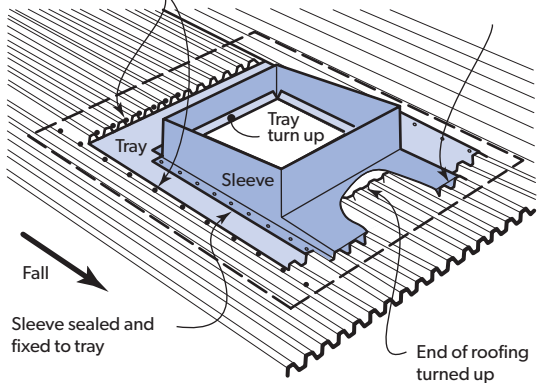
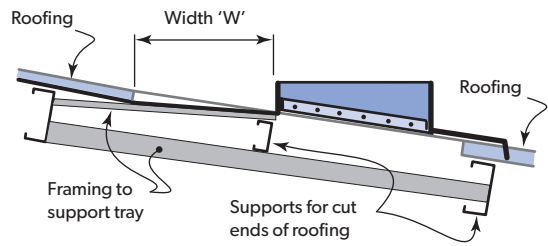
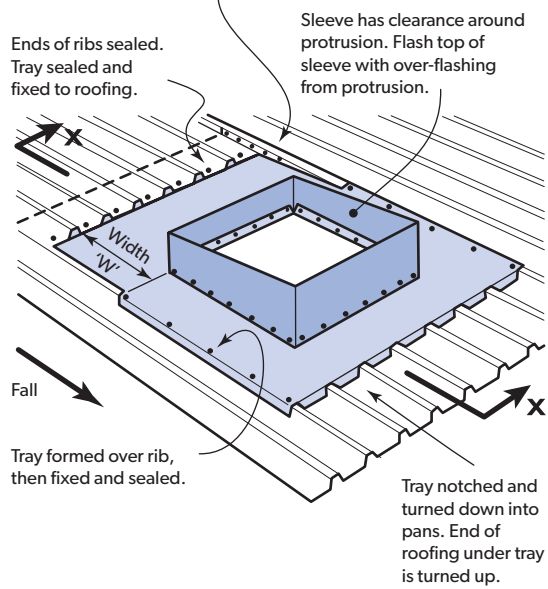

FIGURE 11.5.3:

Flashing method 3: Tray gutter for steeper roofs.

Cut side of roofing rib to match slope of tray. Sides of tray turned up behind cut rib then sealed and fixed to rib.



Section X-X

The base of the tray over width 'W' slopes slightly towards the protrusion. The width 'W' varies with this slope, the roof pitch and the rib height. Thus:

$$W = \frac{\text{Rib Height}}{\sin(\text{roof pitch} - \text{slope of tray})}$$

For example: if the tray slopes 1 in 50 (l) and the roof pitch is 1 in 12 (5).

RIB DEPTH	WIDTH 'W' (minimum)
25mm	360mm
29mm	420mm
41mm	590mm

FIGURE 11.5.4:

Flashing method 4: Penetrations close to ridge capping.

Coated steel tray with 2 sides turned down over ribs. Tray must be supported by roofing underneath.

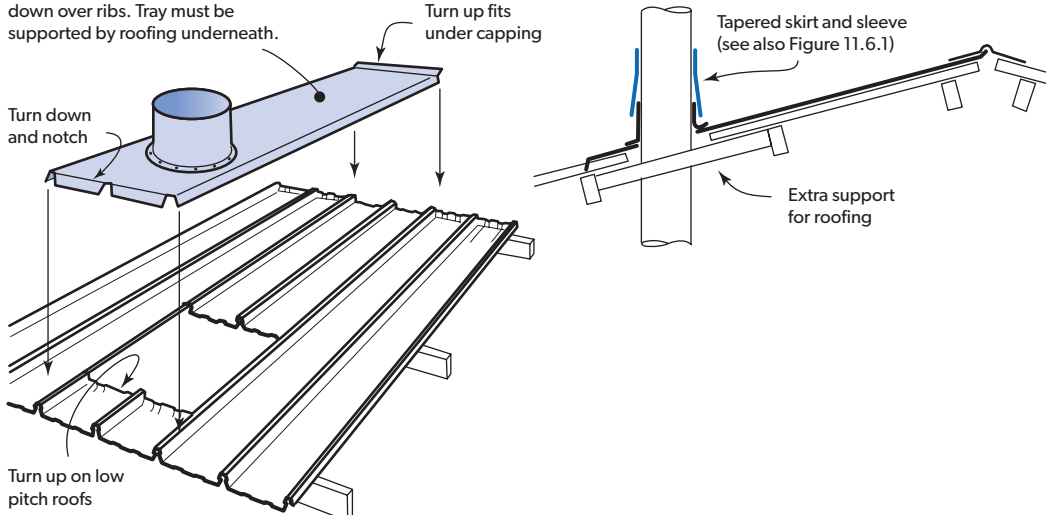

11.6 FLASHING SMALL ROOF PENETRATIONS

A flanged cylindrical sleeve is a fairly simple method of flashing around small penetrations (such as pipe penetrations) which fit between the ribs of a roof sheet, or penetrate only a single rib.

Two methods are described here. Wherever roofing is cut, you must consider providing extra support for the roofing above and below the penetration. Where one or more of the sheet ribs are cut, you must provide framing to support at the cut ends of the roof cladding each side of the penetration.

METHOD 1: TAPERED METAL SKIRT AND SLEEVE

This method uses parts custom-fabricated from metal. There is no positive seal between inside the building and the outside atmosphere (Figure 11.6.1).

METHOD 2: SLEEVE

This is often the simplest method (Figure 11.6.2). Flexible flanged sleeves can be bought for flashing around penetrations of at least 350mm diameter. They overcome the problem of capping and sealing the open ends of cut ribs. A sleeve is commonly used, though silicone sealant has a wider operating temperature range and is available in a wider range of colours.

The flange around the base of the sleeve can be contoured by hand to match the cladding profile before it is sealed and fixed to the cladding.

Be careful not to dam any valleys or pans so that rainwater can drain freely from the high side of the roof penetration. Moisture held in such areas can cause deterioration of the sheet coating, reduced life expectancy or poor appearance.

Where damming of any valley or tray is unavoidable, due to the size of the pipe penetration, treat the installation as a large penetration (Section 11.5).

COPPER PENETRATIONS

All copper pipe penetrations through cladding shaped from ZINCALUME® steel or COLORBOND® steel must be physically and electrically isolated from the cladding. This can be done by using a sleeve of PVC polythene or similar plastic that is also ultra-violet stable.

FIGURE 11.6.1:

Small penetration with metal skirt and sleeve.

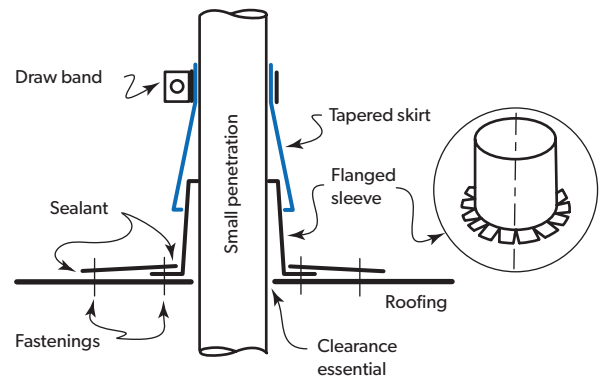
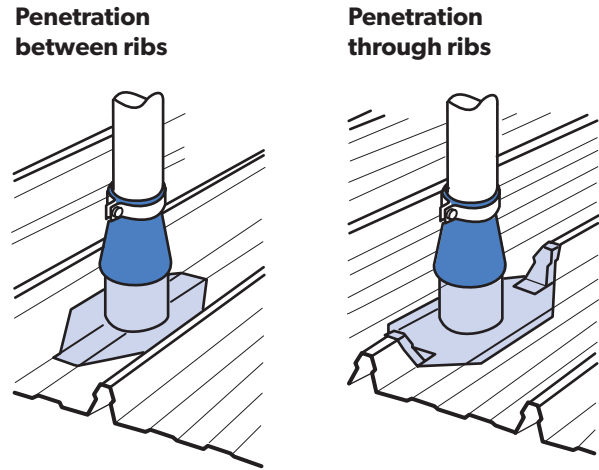
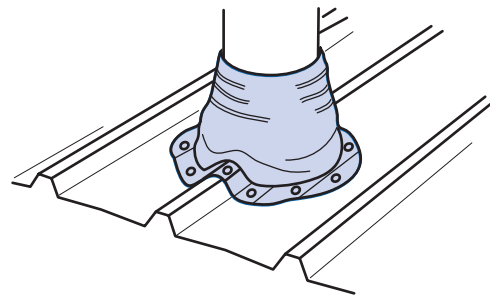

FIGURE 11.6.2:

Small penetration with sleeve. (Dektite® sleeve illustrated).



11.7 FLASHING WALLS

Cladding is usually installed with the profile running vertically or horizontally, though sheets have been laid diagonally—the choice is aesthetic.

Wind can drive rain hard against wall flashings, so it is important that you pay attention to the detailing of flashings around windows, doors, re-entrant and external corners, to ensure you get a watertight building. You also want a neat appearance.

We make wall flashings for some wall claddings (like MINI ORB®) which are sometimes called trims. Where these are not suitable, custom-made flashings can be easily produced following the general principles described in this section.

For more details about flashing LYSAGHT® cladding, please refer to our Flashing Manual which is available on our website or in hard copy.

WALLING PROFILE RUNNING HORIZONTALLY

- It is usual to lay the first sheet at the bottom of a wall and work upwards towards the eaves. You want the window and door flashings to fit properly into the valleys, so you should locate the first sheet relative to the heads and sills of doors and windows. Thus, you first have to decide where the cladding will eventually be located at the heads of doorways and at the heads and sills of windows before you place the first sheet.
- Where possible, select the vertical size of windows so that the flashings at both heads and sills will coincide neatly with the pitch of your profile (Figure 11.7.1).
- Be sure that the crests of the profile align with each other on adjacent walls, either side of a corner—this ensures that horizontal flashings fit properly into all valleys.
- Where valleys create a void at flashings, use closed-cell foam plastic infill (Figure 10.3.3).
- Where wind-driven rain can be expected, turn back the edges of flashing to restrict water movement past the flashing.

FIGURE 11.7.1:

Typical header and sill flashing:
profile running horizontally (elevation).

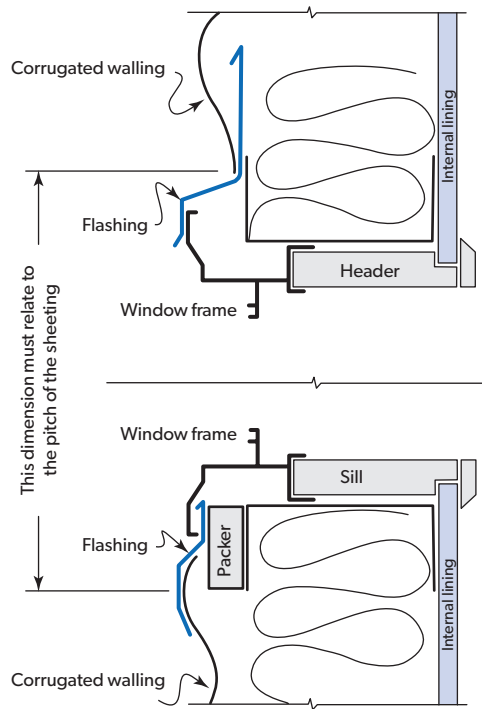
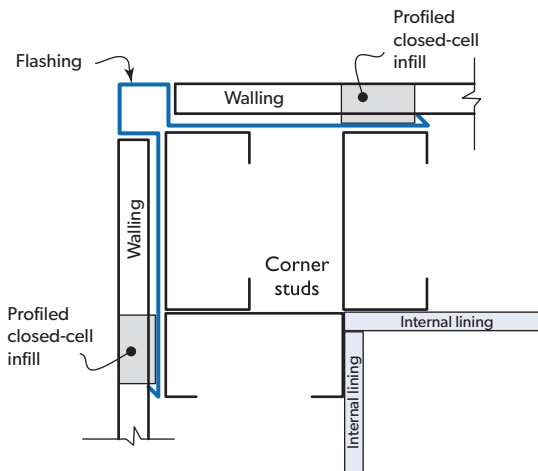

FIGURE 11.7.2:

Typical corner flashings:
profile running horizontally (plan view).

**Typical external corner flashing type 1:
profile running horizontal (plan)**



**Typical re-entrant corner flashing:
profile running horizontal (plan)**

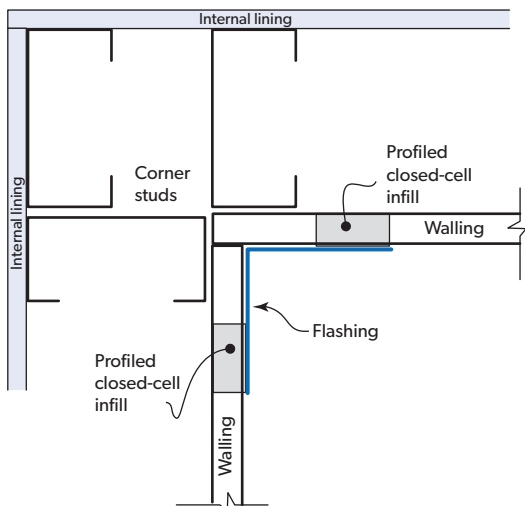

**Typical external corner flashing type 2:
profile running horizontal (plan)**

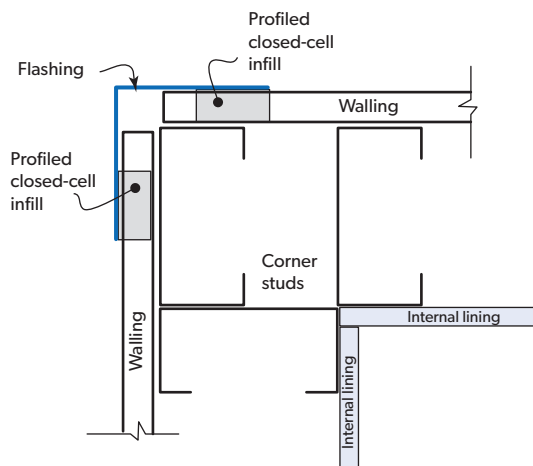
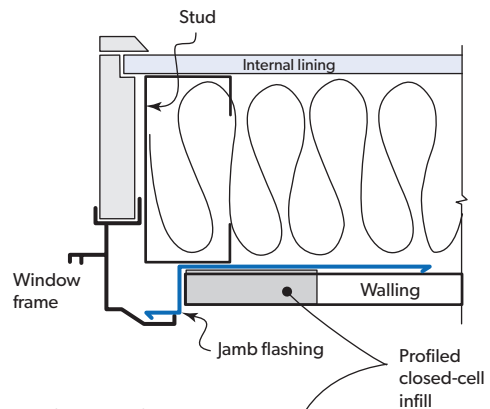
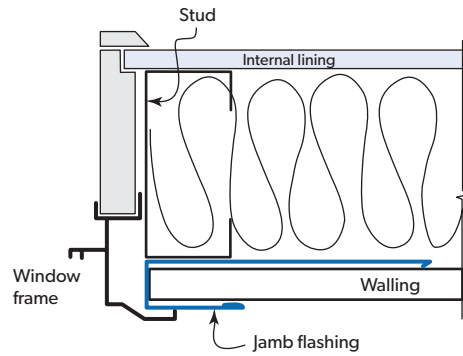

FIGURE 11.7.3:

Typical flashing at window and door jambs:
profile running horizontally.

Plan view option 1



Plan view option 2

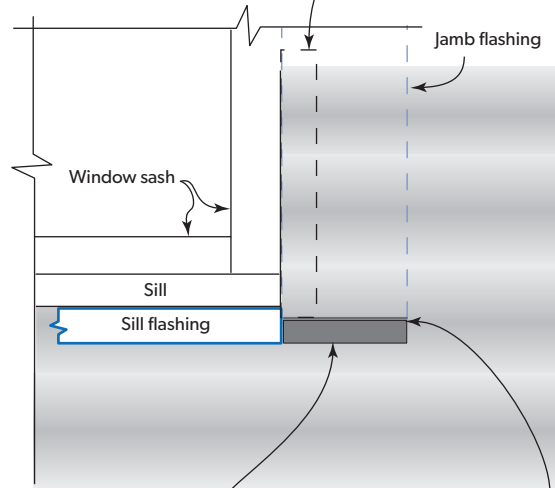

Elevation

Jamb flashing brought to outside through slit in valley of corrugation

WALLING PROFILE RUNNING VERTICALLY

Flashings are generally easier on jobs where the profile runs vertically (Figures 11.7.4 and 11.7.5).

FIGURE 11.7.4:

Typical header and sill flashing: profile running vertically (elevation).

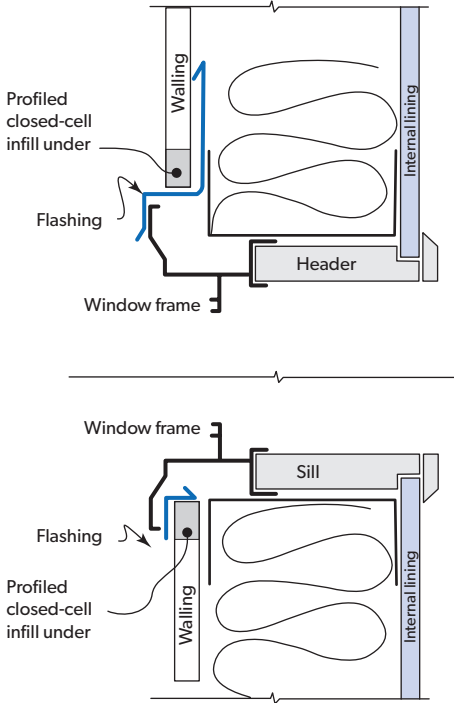
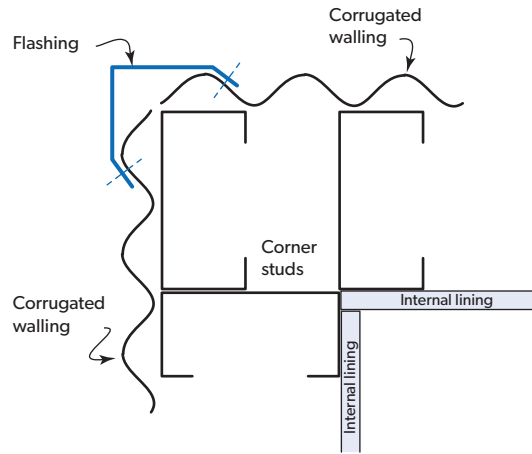

FIGURE 11.7.5:

Typical corner flashings: profile running vertically (plan). Jamb flashings follow same principle.

Typical external corner flashing: profile running vertical (plan)



Typical re-entrant corner flashing: profile running vertical (plan)

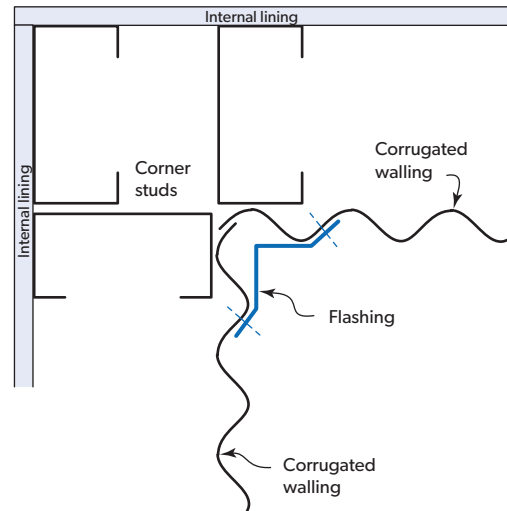

11.8 BUSHFIRE PROTECTION

AS 3959 sets out requirements for the design, detailing and construction of buildings in bushfire prone areas. Some of the details to consider are:

- Gaps to be sealed by mesh, perforated sheet, mineral wool or other non-combustible material (Figure 11.8.1).
- Be sure that flashing fit closely. Transverse flashings should be notched or scribed (Figure 11.3.1).
- At the gutter/discharge end of the roofing the capillary gap may need to be adequately protected to ensure minimal gap against ember entry.
- Turn-down of ribs and blocking off rib cavities, may assist to minimise ember entry (Section 10.2.2 & 10.3).

FIGURE 11.8.1:

Typical protection from sparks at ridge.

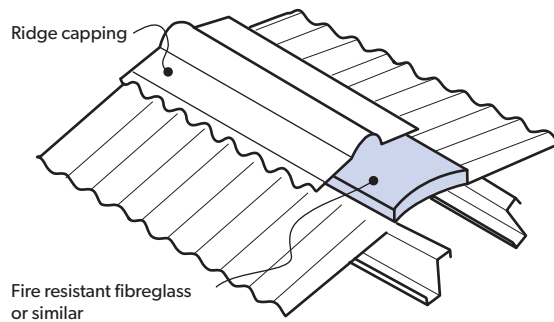

References

AUSTRALIAN STANDARDS

Amongst the publications of Standards Association of Australia, the following are particularly appropriate and may be referenced in this Manual. Where appropriate the most recent revision of the publication should be referenced.

AS/NZS 3500.3:2021

Plumbing and Drainage-Part 3: Storm water drainage

AS 3566.1-2002

Self drilling screws for building and construction Industries Part:1 General requirements and mechanical properties

HB 114:1998

Guidelines for eaves and box gutters

AS 3959:2018

Construction of buildings in bushfire-prone areas

AS 3566.1-2002

Self drilling screws for building and construction Industries Part:1 General requirements and mechanical properties

AS/NZS 2179.1:2014

Specifications for rainwater goods, accessories and fasteners

AS 1397:2021

Continuous hot-dip metallic coated steel sheet and strip — Coatings of zinc and zinc alloyed with aluminium and magnesium

AS 1562.1:2018

Design and installation of metal roof and wall cladding, Part 1: Metal

AS 4040.1-1992 Rec:2016

Methods of testing sheet roof and wall cladding - Method 1: Resistance to concentrated loads

AS 4040.2-1992 (Rec 2016, Amd 1:2018)

Methods of testing sheet roof and wall cladding, Method 2: Resistance to wind pressures for non-cyclone regions

AS/NZS 1170.2:2021

Structural design actions, Part 2: Wind actions

AS/NZS 2728:2013

Prefinished/prepainted sheet metal products for interior/exterior building applications - Performance requirements

SA HB 39:2015

Installation code for metal roof and wall cladding

BLUESCOPE

Amongst the publications of BlueScope, the following are particularly appropriate and may be referenced in this Manual. Where appropriate the most recent revision of the publication should be referenced.

TECHNICAL BULLETINS (GENERAL)

TB-1: Steel roofing and walling products: Selection guide

TB-2: Overpainting and restoration of COLORBOND® pre-painted steel sheet

TB-4: Maintenance of COLORBOND® pre-painted steel roofing

TB-5: Swarf staining of steel roofing and walling profiles

TB-7: Care and Storage of BlueScope Steel coated steel products prior to installation

TB-8: Flashing materials for ZINCALUME® steel & COLORBOND® steel sheet

TB-13: General guide to good practice in the use of steel roofing and walling products

TB-15: Recommended steel gutter systems

TB-16: Fasteners for roofing and walling product: Selection guide

TECHNICAL BULLETINS (CORROSION)

CTB-1: General introduction

CTB-8: Building applications

CTB-10: Roof penetrations

CTB-11: Condensation

CTB-12: Dissimilar metals

CTB-13: Contact with timber

CTB-15: Acid cleaning brickwork

CTB-16: Immersion

CTB-17: Following trades

CTB-18: Painting lead flashing

The full range of TBs and CTBs are available for download from our website: www.steel.com.au/library

OTHER PUBLICATIONS

NCC – Publication of Australian Building Codes Board titled National Construction Code

PCA - Publication of Australian Building Codes Board titled NCC, Volume Three, Plumbing Code of Australia.

BCA - Publication of Australian Building Codes Board titled NCC, Building Code of Australia. There is Volume One and Volume Two for differing building classes.

Index

A		
Alignment of roofing		
Concealed-fixed	38	
Pierced-fixed	34	
Australian Standards	59	
B		
Blocking rib cavities	45	
Bullnosed (See pre-curved roofs)	19	
Bushfire protection	58	
C		
Cappings. See flashings		
Care of products	30	
Clean up	31	
Clips		
for KLIP-LOK®	36	
required quantities	15	
Coatings, strippable	31	
COLORBOND® steel	6	
and painting	8	
avoiding rust stains	31	
Compatibility of materials	7	
drainage table	8	
Concealed-fixing. See installation		
Condensation	24	
Crest fixing	35	
Curving. See roof: curved		
Cutting cladding	30	
Cyclonic		
anchoring footings	4	
conditions	4	
D		
Dektite flashings	55	
Design	6	
roof drainage	27	
roofs	6	
walls	6	
Dissimilar metals.		
See compatibility of materials		
Downpipe size.		
See roof: drainage: downpipe size		
Drainage of roofs.		
See roof: drainage: design		
E		
Effective roof lengths for drainage	11	
End-lapping	46	
expansion	48	
fixing methods	46	
low pitches	47	
order of laying sheets	47	
spacing of supports	47	
Ends of sheets	43	
blocking rib cavities	45	
end-lapping	46	
overhang, stiffened	49	
turn-downs	45	
turn-ups	43	
Environmental conditions	7	
Expansion	48	
Expansion joints	48	
F		
Fasteners	12	
features table	13	
for accessories	14	
for CUSTOM BLUE ORB®	16	
for CUSTOM ORB®	16	
for CUSTOM ORB ACCENT® 21	16	
for CUSTOM ORB ACCENT® 35	16	
for installation	15	
for KLIP-LOK®	17	
for MINI ORB®	17	
for MULTICLAD®	17	
for PANELRIB®	18	
for side-laps	14	
for SPANDEK®	18	
for thicker steels	14	
for transverse flashings	53	
for TRIMDEK®	18	
for TRIMWALL®	18	
for WALLCLAD®	18	
identification	12, 13	
nails	12	
materials	12	
quantity required	14	
rivets, sealing	31	
screws, setting tightness	13	
sealing washers	13	
washers, sealing	13	
Finishes	6	
Flashings	50	
at change of roof pitch	53	
at copper penetrations	55	
at large penetrations	53	
at small penetrations	55	
sleeve	56	
longitudinal	50	
materials	50	
notching	53	
notching tools	51	
notching with tinsnips	52	
transverse	51	
walls	56	
G		
Gutters		
areas	29	
typical types	28	
H		
Handling products	30	
Heat control	23	
Holes	30	
I		
Incompatibility.		
See compatibility of materials		
Infill strips	46	
Information	3	
Installation		
alignment of roofing	33, 38	
concealed-fixing	36	
KLIP-LOK® on walls	41	
KLIP-LOK®	37	
pierce-fixed	34	
crest fixing	35	
procedure	31	
side-laps	34, 35	
valley fixing	35	
Insulation		
fastener length	14	
heat control	23	
materials	25	
noise	25	
thickness limitations	25	

L					
Lengths					
roofing	6				
roofing drainage	11				
transportation	8				
Lifting roofing	33				
M					
Maintenance	32				
Marking out	30				
Materials					
cladding specifications	6				
for fasteners	12				
for flashings	50				
for insulation	25				
N					
Nails. See fasteners					
Noise reduction	25				
Notching. See flashings					
P					
Pencils for marking out	30				
Performance tests	7				
Pierce-fixing. See installation					
Pitches of roofs	7				
Products					
profiles	9, 10				
selection	6				
Profiles of claddings	9, 10				
Q					
Quantities of clips & fasteners	15				
R					
Rainfall intensities table	28				
References	59				
Rivets. See fasteners					
Roof					
alignment of sheets	33, 34				
curved	19				
bullnosed (see pre-curved roofs)	21				
capped bent ribbed	22				
pre-curved	21				
spring-arched	20				
spring-curved	21				
spring-curved-ridge	19				
design	6				
drainage					
design	27				
downpipe locating	27				
downpipe size	27, 28				
gutter areas & downpipes	29				
gutter types	28				
maximum roof lengths	6, 11				
rainfall intensities	28				
lengths (maximum)	11				
roofing drainage	27				
transportation	8				
pitches	7				
tapered	22				
walking on	30				
wind forces	7				
Rust stains					
avoiding	31				
warn other contractors	31				
S					
Safety	30				
guardrails	30				
lifting roofing	33				
walking on roofs	30				
Screws. See also fasteners					
setting tightness	13				
Sealant use	31				
Sealants	31				
Sealing washers	13				
Selection of products	6				
Silicone sealant. See sealants					
Skylighting	23, 26				
Solvents	31, 32				
Spacing definitions	9, 10				
SPANDEK® overlaps	46				
Specifications					
for profiles (tables)	9, 10				
materials	6				
Storage of products	30				
Strippable coatings	31				
Support spacings	6				
T					
Tapered roofing	22				
Technical bulletins	59				
Testing performance	7				
Thermal transmission (see heat control)	23				
Thermatech® technology	23				
Translucent cladding. See skylighting					
Transportation	8				
Trims (see flashings, walls)	56-58				
Turn-downs	43, 45				
Turn-ups	43, 45				
V					
Valley fixing	33, 35				
W					
Walking on roofs	30				
Wall flashings	56				
Walls, design	6				
Warranties	4				
Washers, sealing	13				
Wind forces	7				
Z					
ZINCALUME® steel	6				
Zip. See RoofZip	13				

PRODUCT DESCRIPTIONS

- All descriptions, specifications, illustrations, drawings, data, dimensions and weights contained in this catalogue, all technical literature and websites containing information from Lysaght are approximations only. They are intended by Lysaght to be a general description for information and identification purposes and do not create a sale by description. Lysaght reserves the right at any time to:

- (a) supply Goods with such minor modifications from its drawings and specifications as it sees fit; and
- (b) alter specifications shown in its promotional literature to reflect changes made after the date of such publication.

DISCLAIMER, WARRANTIES AND LIMITATIONS OF LIABILITY

- This publication is intended to be an aid for all trades and professionals involved with specifying and installing Lysaght products and not to be a substitute for professional judgement.
- Terms and conditions of sale available at local Lysaght sales offices.
- Except to the extent to which liability may not lawfully be excluded or limited, BlueScope Steel Limited will not be under or incur any liability to you for any direct or indirect loss or damage (including, without limitation, consequential loss or damage such as loss of profit or anticipated profit, loss of use, damage to goodwill and loss due to delay) however caused (including, without limitation, breach of contract, negligence and/or breach of statute), which you may suffer or incur in connection with this publication.

**FOR DETAILED PRODUCT INFORMATION,
MANUALS AND PROJECT CASE STUDIES VISIT:**

WWW.LYSAGHT.COM

COLORBOND®, ZINCALUME®, LYSAGHT®, BlueScope, the BlueScope brand mark, ® product and product brand names are registered trademarks and ™ product and product brand names are trademarks of BlueScope Steel Limited.

The LYSAGHT® range of products is exclusively made by or for BlueScope Steel Limited trading as Lysaght.

© BlueScope Steel Limited 2024 ABN 16 000 011 058. All rights reserved.

INSPIRATION TO BUILD BETTER

